



# INTERNATIONAL MARINE CERTIFICATION INSTITUTE

International Non-Profit Association

Rue Abbé Cuypers 3 / B-1040 Bruxelles / Belgique / +32 2 741 6836 / +32 2 741 2418  
www.imci.org / info@imci.org

## EC-TYPE EXAMINATION CERTIFICATE

We hereby certify that the product below manufactured by

**X-Yachts A/S**

*Fjordagervej 21 - DK-6100 HADERSLEV - DENMARK*

**Recreational Craft**

**X-40**

**X-40 CLASSIC**

**X-40 MODERN**

**X-40 SPORT**

	Design & Construction
Scope	B
Module type	Sail
Boat type	A
Boat design category	12,19
Length of hull [m]	3,8
Beam of hull [m]	9178
Loaded displacement mass [kg]	27,4
Maximum rated engine power [kW]	10
Number of persons recommended	1375
Maximum recommended load [kg]	
Certificate number	BXYACHTS017

*meets the requirements of the Recreational Craft  
Directive 94/25/EC as amended by 2003/44/EC*



*Dirk Heinemann* (Managing Director)  
for EU - Notified Body : 0609

2006-11-17

This certificate is valid for craft identified as a  
2007 model

References to the relevant standards used are given on the Declaration of Conformity



NBN EN 45011 accredited organisation - Certificate No 070 PR

## CONTENTS

<b>CONTENTS</b>	<b>1</b>
<b>WELCOME ABOARD</b>	<b>3</b>
THIS MANUAL	3
SAFETY	3
SAFETY PRECAUTIONS	3
SYMBOLS USED IN CRAFT	4
DESIGN CATEGORY	6
ENVIRONMENTAL CONSIDERATIONS	6
BEFORE DEPARTURE	6
DURING SAILING	7
BEFORE DISEMBARKING	7
ENGINE BASICS	7
WARRANTY CONDITIONS	8
DESCRIPTION OF YACHT	9
<b>SYSTEMS AND CIRCUITS</b>	<b>10</b>
WATER TANK SYSTEM	11
FRESH WATER CIRCUIT	12
FRESH WATER CIRCUIT (2-CABIN)	13
HOT WATER CIRCUIT	14
HOT WATER CIRCUIT (2-CABIN)	15
HOLDING TANKS (OPTIONAL)	16
HOLDING TANKS 2-CABIN	16
SEACOCKS AND THROUGH HULL FITTINGS	17
SEACOCKS AND THROUGH HULL FITTINGS (2-CABIN)	18
DRAINING SYSTEM	19
DRAINING SYSTEM (2-CABIN)	20
SHOWER SUMP SYSTEM	21
SHOWER SUMP SYSTEM (2-CABIN)	22
FUEL SYSTEM	23
GAS SYSTEM	24
ELECTRICAL INSTALLATIONS	26
FIRE-EXTINGUISHING SYSTEM	28

<b>GENERAL MAINTENANCE</b>	<b>30</b>
<b>HULL AND DECK</b>	<b>30</b>
<b>GENERAL MAINTENANCE</b>	<b>30</b>
<b>CLEANING</b>	<b>30</b>
<b>WAXING</b>	<b>30</b>
<b>POLISH</b>	<b>30</b>
<b>REMOVAL OF DISCOLOURING</b>	<b>30</b>
<b>DAMAGES</b>	<b>31</b>
<b>SCRATCHES</b>	<b>31</b>
<b>BOTTOM TREATMENT</b>	<b>31</b>
<b>CATHODIC PROTECTION</b>	<b>31</b>
<b>DECK HARDWARE AND RIGGING</b>	<b>31</b>
<b>DECK GEAR AND HARDWARE</b>	<b>32</b>
<b>RUNNING RIGGING</b>	<b>32</b>
<b>STANDING RIGGING</b>	<b>32</b>
<b>SAILS</b>	<b>32</b>
<b>MAST, BOOM AND SPINNAKER POLE</b>	<b>32</b>
<b>CANVASES</b>	<b>33</b>
<b>SPRAYHOOD AND COCKPIT COVERS</b>	<b>33</b>
<b>INTERIOR</b>	<b>33</b>
<b>LACQUERED WOODEN SURFACES</b>	<b>33</b>
<b>LAYING-UP AND WINTER STORAGE</b>	<b>34</b>
<b>LIFTING</b>	<b>34</b>
<b>LIFTING WITH SLINGS</b>	<b>34</b>
<b>SINGLE-POINT LIFT</b>	<b>34</b>
<b>CRADLE</b>	<b>34</b>
<b>HULL AND DECK</b>	<b>34</b>
<b>CLEANING</b>	<b>35</b>
<b>GENERAL WINTERISATION</b>	<b>35</b>
<b>APPENDIX</b>	<b>36</b>
<b>DECK LAYOUT</b>	<b>37</b>
<b>ANCHORING ARRANGEMENTS</b>	<b>35</b>
<b>PROFILE/SAIL PLAN</b>	<b>39</b>
<b>PROFILE/SAIL PLAN</b>	<b>39</b>
<b>PROPULSION ARRANGEMENT</b>	<b>38</b>
<b>ELECTRICAL INSTALLATION DIAGRAMS</b>	<b>42</b>

FEJL! BOGMÆRKE ER IKKE DEFINERET.

## WELCOME ABOARD

### This manual

This manual has been compiled to help you to operate your craft with safety and pleasure. It contains details of the craft; the equipment supplied or fitted, its systems, and information on its operation and maintenance.

Please read this and all operating instructions for extra equipment carefully, and familiarize yourself with the craft and the equipment before commissioning it.

If this is your first craft, or you are changing to a type of craft you are not familiar with, for your own comfort and safety, please ensure that you obtain handling and operating experience before assuming command of the craft. Your dealer or national sailing federation or yacht club will be pleased to advise you of local sea schools, or competent instructors.

**PLEASE KEEP THIS MANUAL IN A SECURE PLACE, AND HAND IT OVER TO THE NEW OWNER WHEN YOU SELL THE CRAFT.**

### Safety

Owner/operator should read and understand all contents of this manual with respect to all the cautions and warnings implied.

It is the responsibility of the owner/operator to ensure that all the craft's safety equipment is present and working as well as it is the duty of the owner/operator to inform his crew of the usage of this equipment and other emergency procedures.

In order to obtain the best possible safety level, we recommend that the safety equipment aboard meets the requirements from "Offshore Racing Council - Special Regulations", which can be ordered from:

Offshore Racing Council Ltd, London, UK  
Phone +44 (0) 1716 298 701  
Fax +44 (0) 1716 293 220

In case of "man overboard", using the bathing ladder will be the easiest way to get the person(s) back aboard.

Always ensure that all escape routes and companionways are clear and escape hatches are unlocked when people are aboard.

Electronic navigational devices such as GPS, chart plotter and radar do not substitute basic navigational knowledge and proper watch keeping. Electronic charts should be updated as well as regular charts. Every craft should carry a minimum of traditional navigational aids as a backup in case of electrical blackout.

### Safety precautions

This manual contains a number of safety precautions for you, your crew and the craft's safety. They are divided into three categories, i.e. degrees of danger that are defined and emphasized as shown below:

#### DANGER

Denotes an extreme intrinsic hazard exists which would result in high probability of death or irreparable injury if proper precautions are not taken.

#### WARNING

Denotes a hazard exists which can result in injury or death if proper precautions are not taken.

#### CAUTION

Denotes a reminder of safety practices or direct attention to unsafe practices which could result in personal injury or damage to the craft or components.

**Symbols used in craft**

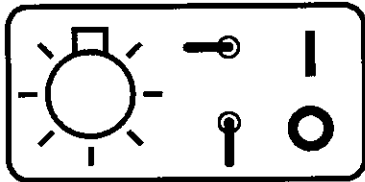

Main switch: Light and service circuit.

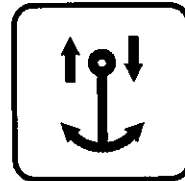

Main switch/automatic fuse: Electric anchor winch.

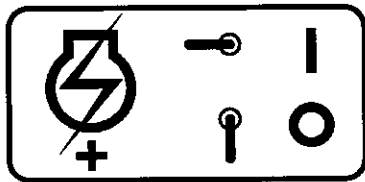

Main switch: Positive conductor main engine.

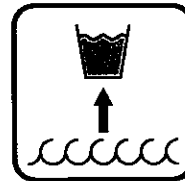

Main switch/automatic fuse: Water maker.

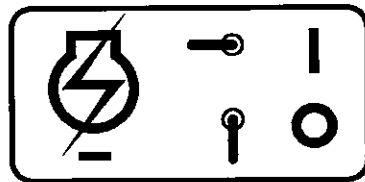

Main switch: Negative conductor main engine.

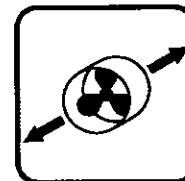

Main switch/automatic fuse: Bow thruster.



Main switch/automatic fuse: Electric winches





Fire escape hatch.

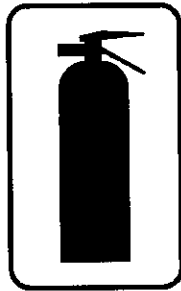

Portable fire extinguisher.

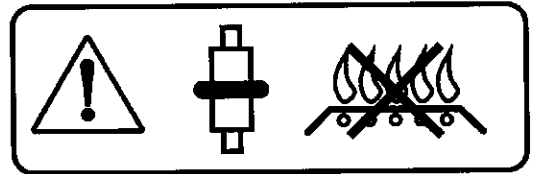

Shut off valve on gas line to cooking unit.

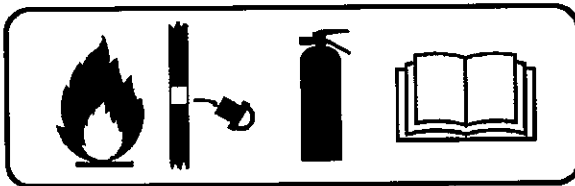

Fire port allowing fire extinguisher to be discharged through the hole into engine compartment in case of fire. Refer to manual for further instruction (evacuate accommodation before discharging).

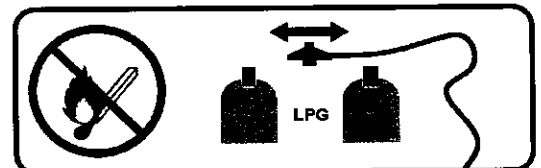

No open flame and no smoking when changing gas cylinders.

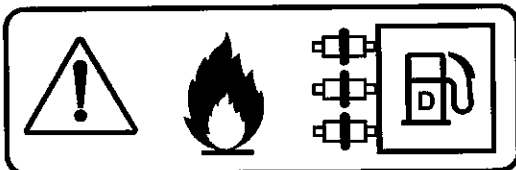

In case of fire, close all shut off valves on fuel tank.

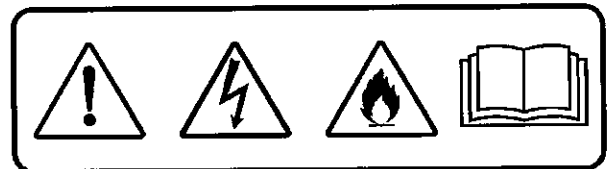

Warning, risk of electrical hazard and fire if proper precautions are not taken. Refer to manual.

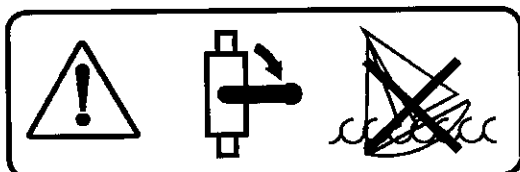

Close all seacocks not in use to minimize risk of flooding.

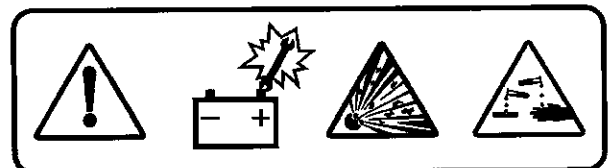

Warning, risk of explosion and leaking of caustic fluid if batteries are short-circuited between battery poles or from batteries to other conducting material i.e. the engine block.



Warning, risk of electrical hazard. Refer to manual before using the shore power inlet.

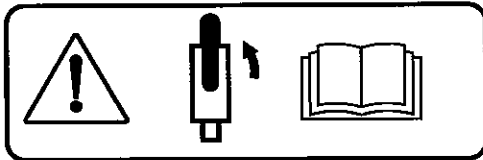

Open overboard valve in toilet before operating macerator pump. Pumping against a closed valve will cause damage to the pump instantly.

## Design category

X-43 is designed and built to meet the requirements of category A - "ocean", which is defined as:

A boat given category A is designed to operate in waves up to 7 m significant height and winds Beaufort force 10 or less, and to survive in more severe conditions. Such as may be encountered on extended voyages, for example across oceans, or inshore when unsheltered from the wind and waves for several hundred nautical miles. Winds are assumed to gust to 28 m/s.

## Environmental considerations

Careful consideration to the environment must be given at all times. Use of solvents should be kept to a minimum and wherever possible only used when the craft is laid-up and suitable drainage is provided. Discharge from marine toilets must be in accordance with local and international laws, and domestic and galley waste should at no time be disposed of overboard when the craft is in inshore waters. In some areas operable direct overboard-waste discharge systems are prohibited. Discharge seacocks are sealable and should be sealed if required. Discharge of fuel and oily waste in navigable waters is prohibited. Consult your marine dealer about environmental regulations when purchasing cleaning agents, paint and other products of this kind.

## Before departure

### DO THIS:

- Open gas shut off valve in the gas box and ensure there are no leaks.
- Turn on main switches for engine and light installations.
- Open inlet seacock for engine cooling water.
- Close discharge seacocks for wastewater.
- Close windows and hatches.

### CHECK THAT:

- Present weather and weather forecast provides safe sailing conditions.
- All necessary equipment is on board. Pay special attention to safety equipment.
- Passengers and crew are instructed in emergency procedures and use of safety equipment.
- Emergency exits are accessible and unlocked.
- The draining system is working and clean.
- The fuel system is not leaking and inspect fuel filter for clogs.
- The craft carries sufficient fuel (with a safety margin). We encourage you to keep a log on fuel consumption and not rely entirely on the level gauge.
- Shut off valves on fuel tank are open.
- The engine compartment is free for fumes of any kind.
- Battery and charging system is in good condition.
- Navigation lights are working and replacement bulbs are available.
- The steering system is working smoothly and properly.
- Navigation instruments and devices are fully functional and calibrated.

## During sailing

Always ensure that all actions on board the craft are carried out in the safest possible way. Remember that when at sea, medical assistance and assistance in general is usually far away.

Pay attention to the present weather and weather forecast. In rough weather always use safety harness, both on deck and in the cockpit. Use hooking points placed in various positions on the craft e.g. pad eyes on the steering pedestal. Place companionway door sections in the slides and secure them.

It is recommendable that all persons aboard wear life jackets.

## Before disembarking

### DO THIS:

- Turn off main switches for engine and light installations.
- Close all inlet seacocks.
- Close gas shut off valve in gas box.
- Lock all doors, hatches etc.
- Place all safety equipment beyond reach of thieves and vandals.

### CHECK THAT:

- The bilge is clean and dry (no signs of leaks).
- The electric bilge pump is working and in automatic activation mode.

## Engine basics

The engine operating and maintenance manual, delivered with your craft, describes everything concerning the engine. The following notes are basic reminders, and are not intended to cover every detail of operating the engine. We urge you to thoroughly read and understand the manual. Remember that you need to have an authorized Volvo dealer to do a 20-hour service check in order to uphold the warranty.

Before starting the engine, always ensure that the cooling water intake seacock is open. Turn on the engine main switch. Press the black clutch button while pushing the throttle control lever approx. 45° forward.

The engine is now in neutral with some throttle, and the engine is ready to be started on the instrument panel. Turn on the ignition. Warning lights for oil pressure and battery charge turn on together with a buzzer. Press the start button or turn the ignition key a bit further (depending on model) and let go when the engine starts.

After a few seconds, the warning lights and the buzzer turn off. Now pull the throttle control lever back to neutral and then push it forward or pull it back, depending on the direction you want the craft to move.

When stopping the engine, pull the throttle control lever to neutral and stop the engine by pulling the stop handle or pressing the stop button (depending on model). When the engine stops, turn off the ignition. If you continue by sail, pull the throttle control lever into reverse position allowing the propeller blades to adjust into sail position.

### **CAUTION**

The boat must not sail more than 4-5 knots when allowing the propeller blades to adjust into sail position, otherwise the gear may be damaged.

When shifting from forward to reverse or visa versa, wait a few seconds in neutral till the engine runs idle.

Keep both hands on steering wheel or tiller and hold on tight when engine is running in reverse.

Refer to engine manual concerning running a new engine with respect to maximum revolutions and load etc.

The engine is fitted with a vacuum valve to prevent seawater from siphoning into the engine block. This valve must be taken apart at least twice a season in order to function properly. Refer to separate manual.



## Warranty conditions

On receipt of the goods, the buyer is obliged to check the goods. Warranty claims must be at X-Yachts A/S' hand 8 days after receipt of the goods in order to make claims on missing items valid. In case of any warranty, the item bought must be returned to X-Yachts A/S right after the claim has been put forward, without expenses for X-Yachts A/S.

Items can only be returned to X-Yachts A/S in case of written agreement in advance. Items returned must be found in same good condition as when delivered from X-Yachts A/S.

Defective delivery can only be advanced towards X-Yachts A/S within 24 months from date of delivery and only within the extent of which X-Yachts A/S' sub suppliers are responsible to X-Yachts A/S. Defects beyond this are without responsibility on X-Yachts A/S' part. To the extent of which X-Yachts A/S is responsible, X-Yachts A/S can choose to correct the defect either by remedy such as replacement, repair, additional supply, or credit. If X-Yachts A/S chooses to remedy the defect, the time spent for this cannot be pleaded delay.

X-Yachts A/S is only responsible for the damage caused by the goods bought, if it can be proved that the damage is due to fault made by X-Yachts A/S.

X-Yachts A/S gives a 5-year's guarantee against osmosis provided:

- a) The boat is ordered with bottom treatment (epoxy barrier and antifouling).
- b) The boat is out of water minimum 8 weeks every year.
- c) The boat has new approved antifouling every year.
- d) The boat has not had any repair made on hull, keel and rudder including the epoxy barrier by others than X-Yachts A/S or representatives of X-Yachts.

**Description of yacht**

Model:	<b>X-40</b>
Version:	Classic
Design category:	"A" (ocean sailing)
Designer:	Niels Jeppesen

Yard:	<b>X-Yachts A/S</b>
Address:	Fjordagervej 21 6100 Haderslev, Denmark
Phone:	+45 74 52 10 22

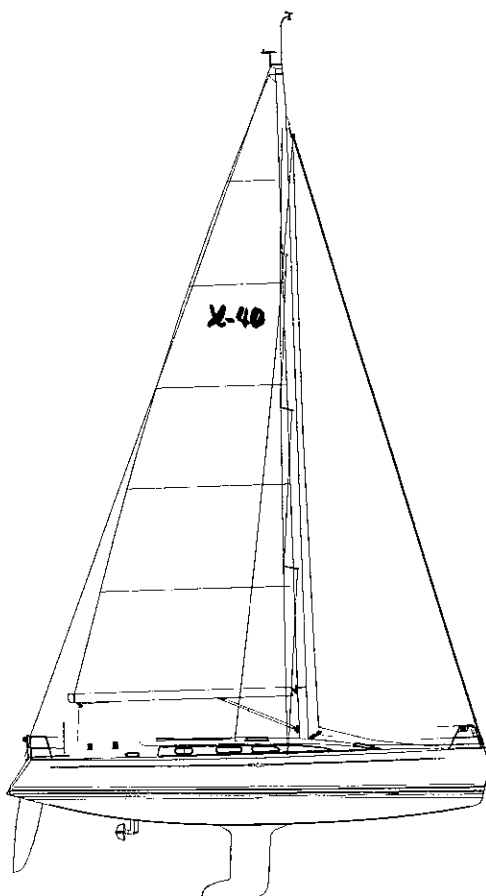

**Main dimensions**

L <sub>HULL</sub> :	12.19 m
L <sub>WL</sub> :	10.71 m
B <sub>MAX</sub> :	3.80 m
Draft fully loaded:	2.46/ 2.16/ 1.86 m
Air draft (excl. windex etc.):	19.00 m
Displacement fully loaded:	9178 kg
Ballast std. approx.:	3200kg
Engine:	29kW

**Sail areas**

Main:	50.55 m <sup>2</sup>
Genoa 1 135%:	48.58 m <sup>2</sup>
Genoa 3 108%:	38.86 m <sup>2</sup>
Genoa 4 85%:	30.58 m <sup>2</sup>
Furling jib 90%:	32.38 m <sup>2</sup>
Selftacking jib 85%:	30.64 m <sup>2</sup>
Spinnaker:	120.8 m <sup>2</sup>
Asymmetrical spinnaker:	120.8 m <sup>2</sup>

**Tank capacities**

Diesel tank:	80/100 litres
Fresh water tank:	180 litres
Holding tanks 2 pieces (extra):	56 litres + 37 litres
Gas cylinders, butane:	2-3 kg

**Misc. capacities**

Service batteries:	12 V 120 Ah
Engine start battery:	12 V 55 Ah
Max No of people:	10 people
Max load (cargo and/or people):	1375 kg

## SYSTEMS AND CIRCUITS

- **Water tank system**
- **Fresh water circuit**
- **Hot water circuit**
- **Holding tanks (extra)**
- **Seacocks and through-hull fittings**
- **Draining system**
- **Shower drain system**
- **Fuel system**
- **Gas system**
- **Electrical installations**
- **Fire-extinguishing system**

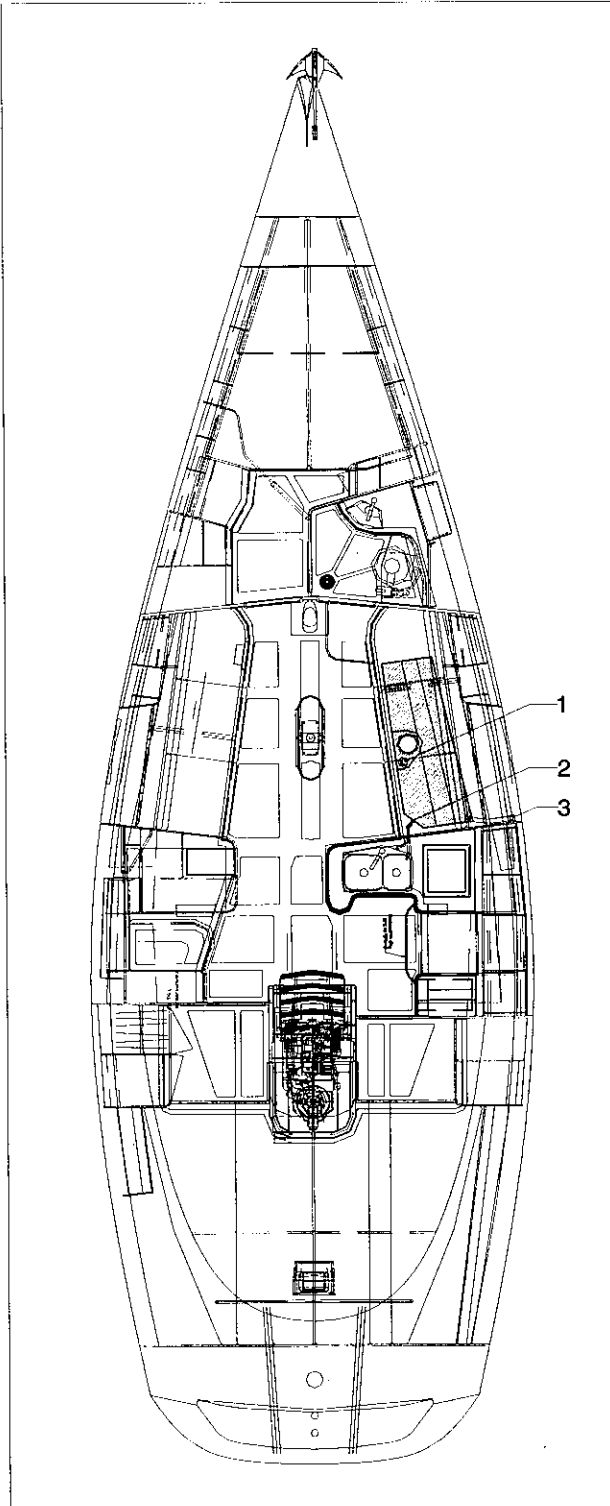

## Water tank system

1. Fresh water tank gauge.
2. Vent line.
3. Deck fill fitting.

The standard 180-liter fresh water tank is filled through the deck fill fitting in SB side.

The tank can be sterilized by adding chlorine tablets (available from chemists), but read and follow instructions carefully.

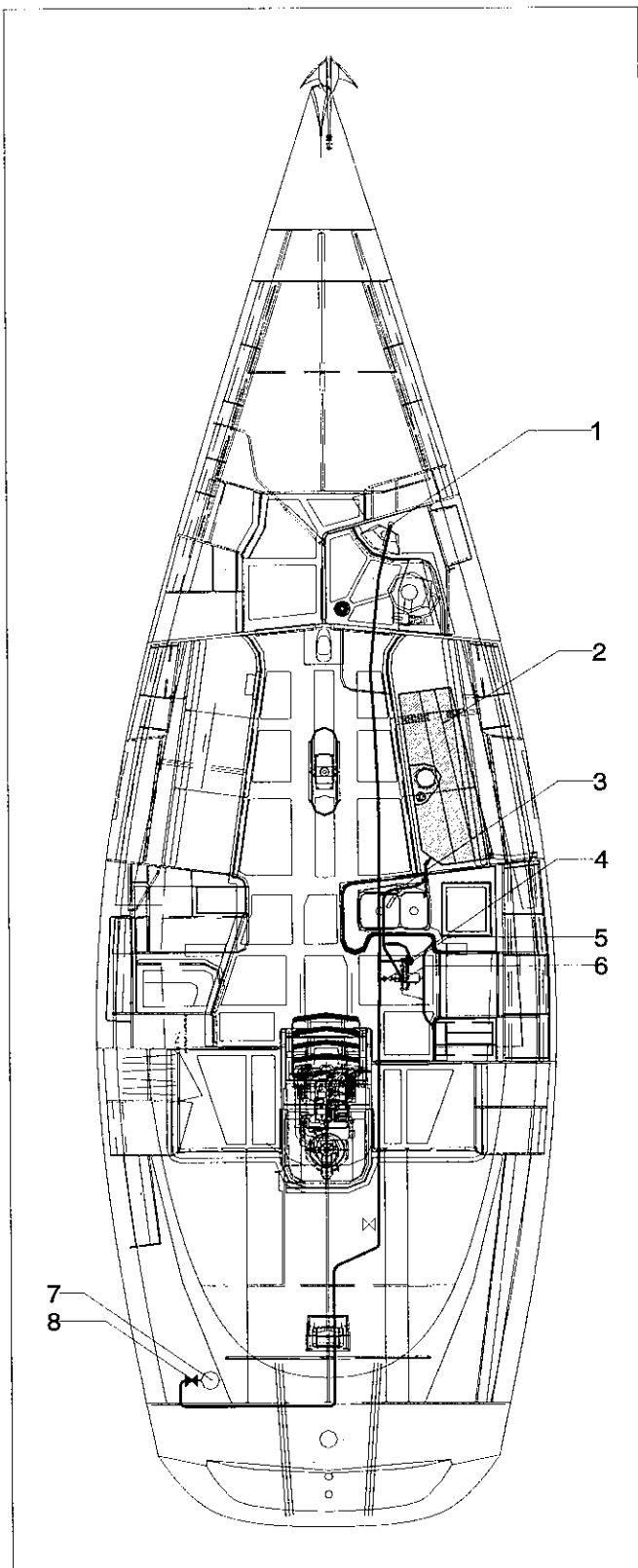

## Fresh water circuit

1. Fwd toilet cold water mixer tap.
2. Freshwater tank
3. Pantry cold water mixer tap.
4. Manual fresh water pump (optional).
5. One-way valve (only if manual pump is installed).
6. Electric fresh water pump.
7. Cockpit shower mixing unit (optional).
8. Shutoff valve for cockpit shower.

The fresh water is distributed from the water tank, placed in the starboard side of the saloon under the sofa seat. The electric fresh water pump is placed under the floor in the pantry.

The pump is an automatic electric driven pressure pump. The pump is turned on at the main electrical panel on the switch labelled "Fresh water pump".

The optional manual freshwater pump can be used in case of a malfunction on the electrical pump.

### CAUTION

Always ensure that there is sufficient fresh water content for your anticipated usage.

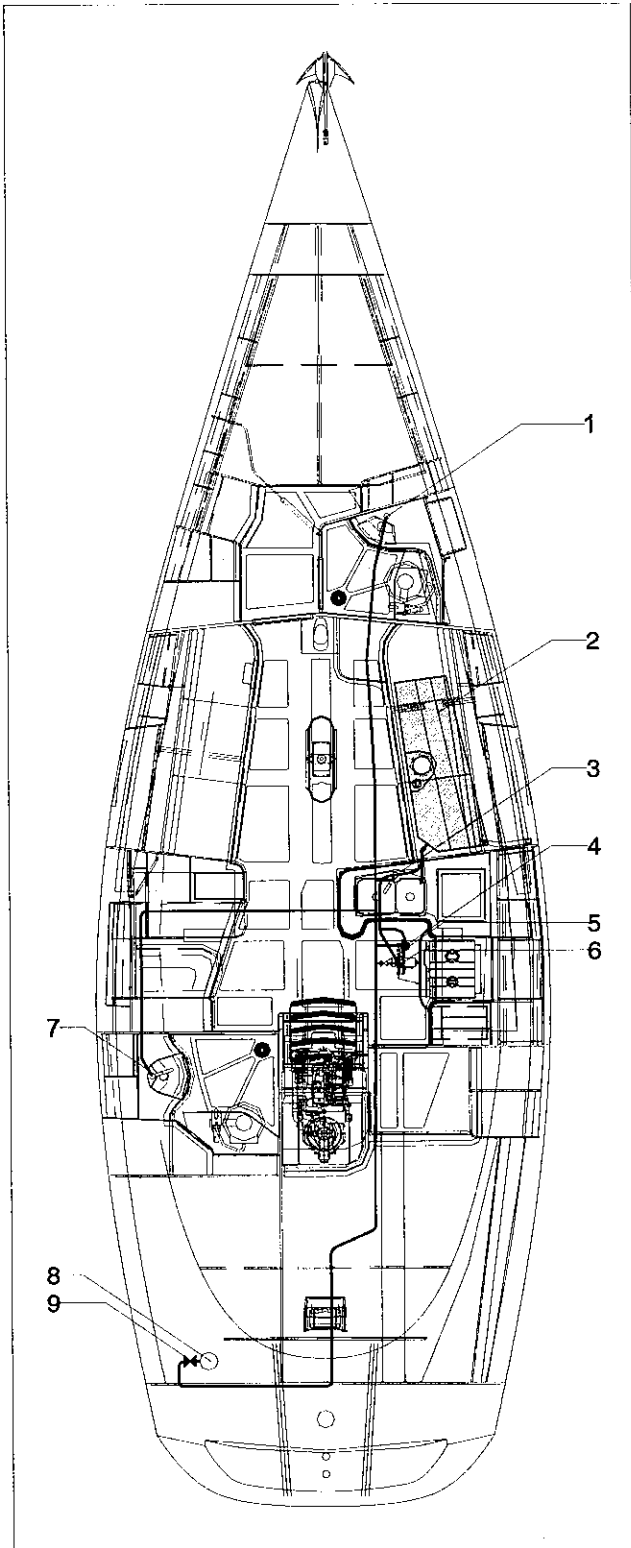

## Fresh water circuit (2-cabin)

1. Fwd toilet cold water mixer tap.
2. Freshwater tank.
3. Pantry cold water mixer tap.
4. Manual freshwater pump (optional).
5. One-way valve (only if manual pump is installed).
6. Electric freshwater pump.
7. Aft toilet warm water mixer tap.
8. Cockpit shower mixing unit (optional).
9. Shutoff valve for cockpit shower.

The fresh water is distributed from the water tank, placed in the starboard side of the saloon under the sofa seat. The electric fresh water pump is placed under the floor in the pantry.

The pump is an automatic electric driven pressure pump.

The pump is turned on at the main electrical panel on the switch labelled "Fresh water pump".

The optional manual freshwater pump can be used in case of a malfunction on the electrical pump.

### **CAUTION**

Always ensure that there is sufficient fresh water content for your anticipated usage.

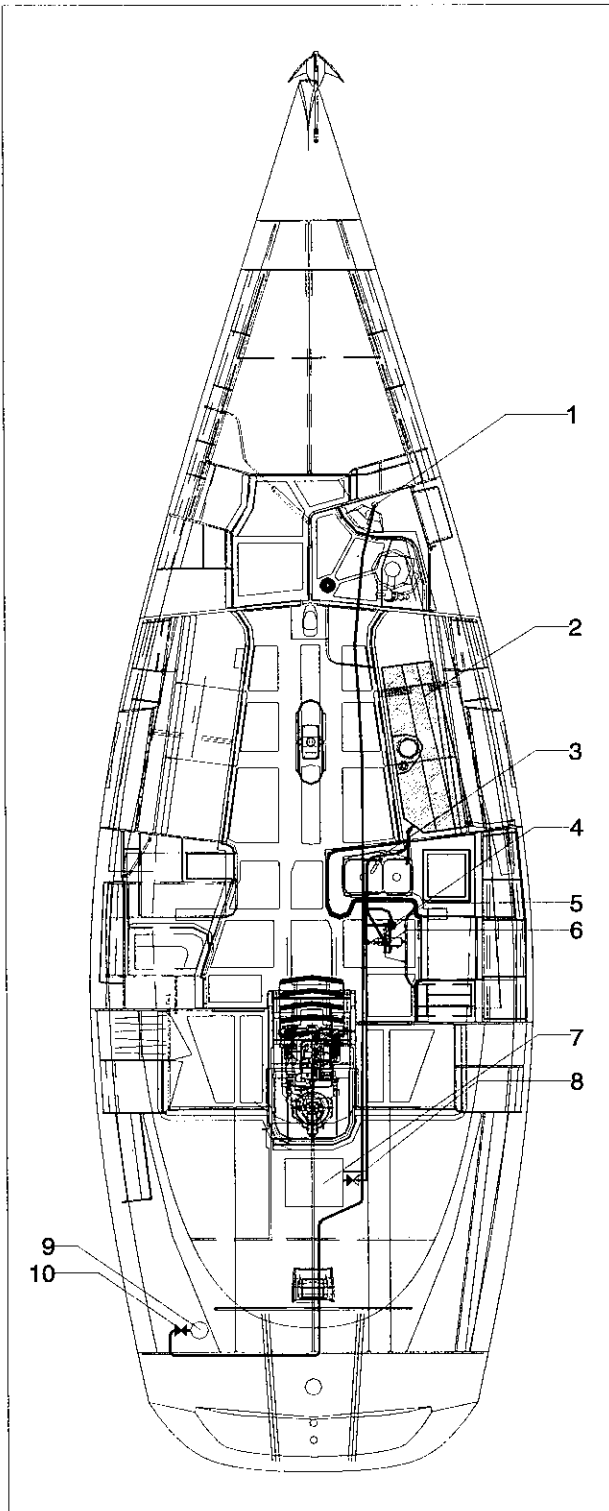

## Hot water circuit

1. Fwd toilet hot water mixer tap.
2. Fresh water tank.
3. Pantry hot water mixer tap.
4. One-way valve (only if manual pump is installed).
5. Fresh water pump.
6. Manual freshwater pump (optional).
7. Water heater.
8. One-way valve.
9. Cockpit shower mixer unit.
10. Shut off valve.

The water heater is able to heat the fresh water in two different ways:

- 1) The water heater is connected to the fresh water-cooling system of the engine. When the engine is running, the cooling water is led through the water heater, heating up the cold fresh water. The hot water tank is very well insulated and the water remains hot for several hours after the engine has stopped.
- 2) The water heater is also equipped with an electrical heating element connected to the 230V shore power system. The heating element is turned on at the shore power distribution panel. A thermostat on the unit controls the temperature of the water.

The hot water tank is automatically filled, when the fresh water pump is turned on. When filling the unit, open a hot water tap to bleed the system. Please refer to the manual for further operational instructions.

The system is installed with a thermostat-controlled mixer valve, which can be adjusted to deliver water at the wanted temperature.

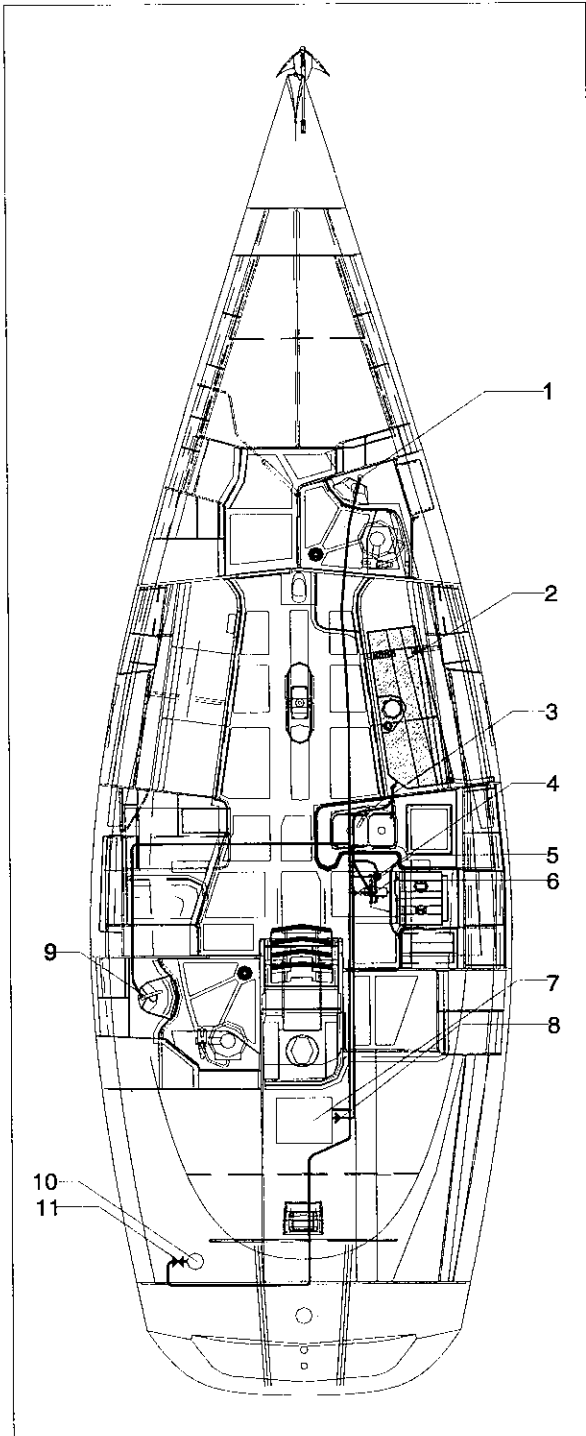

## Hot water circuit (2-cabin)

1. Fwd toilet hot water mixer tap.
2. Fresh water tank.
3. Pantry hot water mixer tap.
4. Manual freshwater pump (optional).
5. One way valve  
(only if manual pump is installed).
6. Electric freshwater pump.
7. Water heater.
8. One-way valve.
9. Aft toilet hot water mixer tap.
10. Cockpit shower mixer unit.
11. Shut off valve.

The water heater is able to heat the fresh water in two different ways:

- 1) The water heater is connected to the fresh water-cooling system of the engine. When the engine is running, the cooling water is led through the water heater, heating up the cold fresh water. The hot water tank is insulated very well, and the water remains hot for several hours after the engine has stopped.
- 3) The water heater is also equipped with an electrical heating element connected to the 230V shore power system. The heating element is turned on at the shore power distribution panel. A thermostat on the unit controls the temperature of the water.

The hot water tank is automatically filled, when the fresh water pump is turned on. When filling the unit, open a hot water tap to bleed the system. Please refer to the manual for further operational instructions. The system is installed with a thermostat-controlled mixer valve, which can be adjusted to deliver water at the wanted temperature.

### CAUTION

The water heater must not be allowed to run dry whilst in use with shore power. This will damage the heating element. Do not turn on the electric water-heating element if the freshwater tank is empty.

### CAUTION

To prevent corrosion when connected to shore power, the hot water tank must be disconnected when not in use. Disconnect by pulling out the 230V AC plug fitted near the hot water tank.



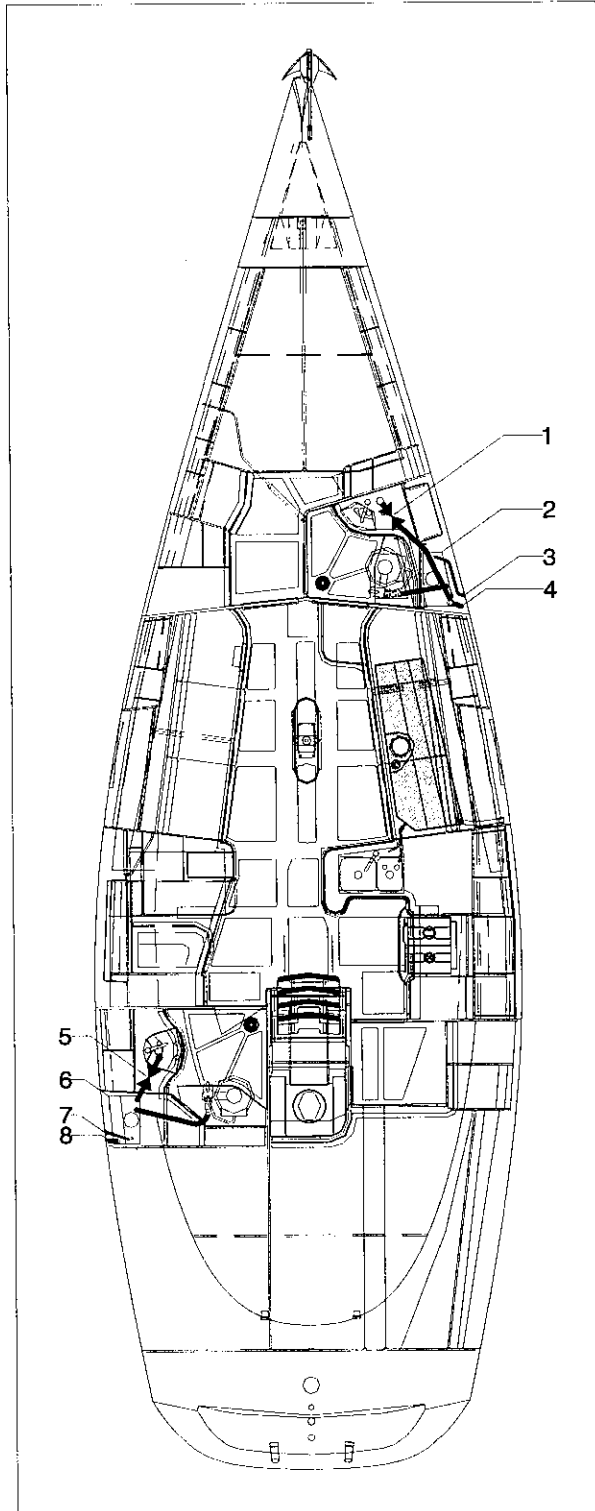

## Holding tanks (optional)

1. Seacock.
2. Forward holding tank.
3. Vent line forward holding tank.
4. Pump-out deck fitting for forward holding tank.

**Capacity of fwd holding tank**  
Approx 28 flushes at 2 litres per flush.

## Holding tanks 2-cabin

The picture shown is of a 2-cabin version.

5. Seacock.
6. Aft holding tank.
7. Vent line aft holding tank.
8. Pump-out deck fitting for aft holding tank.

**Capacity of aft holding tank:**  
Approx 18 flushes at 2 litres per flush.

There are two ways of draining out the holding tanks:

- 1) Through the pump-out deck fitting. The tanks can be drained out using a wastewater vacuum station, which is available in selected harbours.
- 2) Opening the seacock can carry direct discharge to sea; gravity will then empty the tanks.

When sailing in areas where wastewater discharge is prohibited, we recommend that the seacocks be sealed in closed position.

### CAUTION

Direct discharge of wastewater to the sea must be done in accordance with local and international laws.

### CAUTION

Only use decomposing and cleaning chemicals made for use in holding tanks. We recommend Aqua chemical Green and Aqua Rinse.

Only toilet paper, made for chemical toilets, must be used. We recommend Aqua Soft.

Maintenance is carried out by rinsing the whole system with seawater. This is done by operating the pump on the toilet.

The whole system must be empty during storage at freezing temperatures.

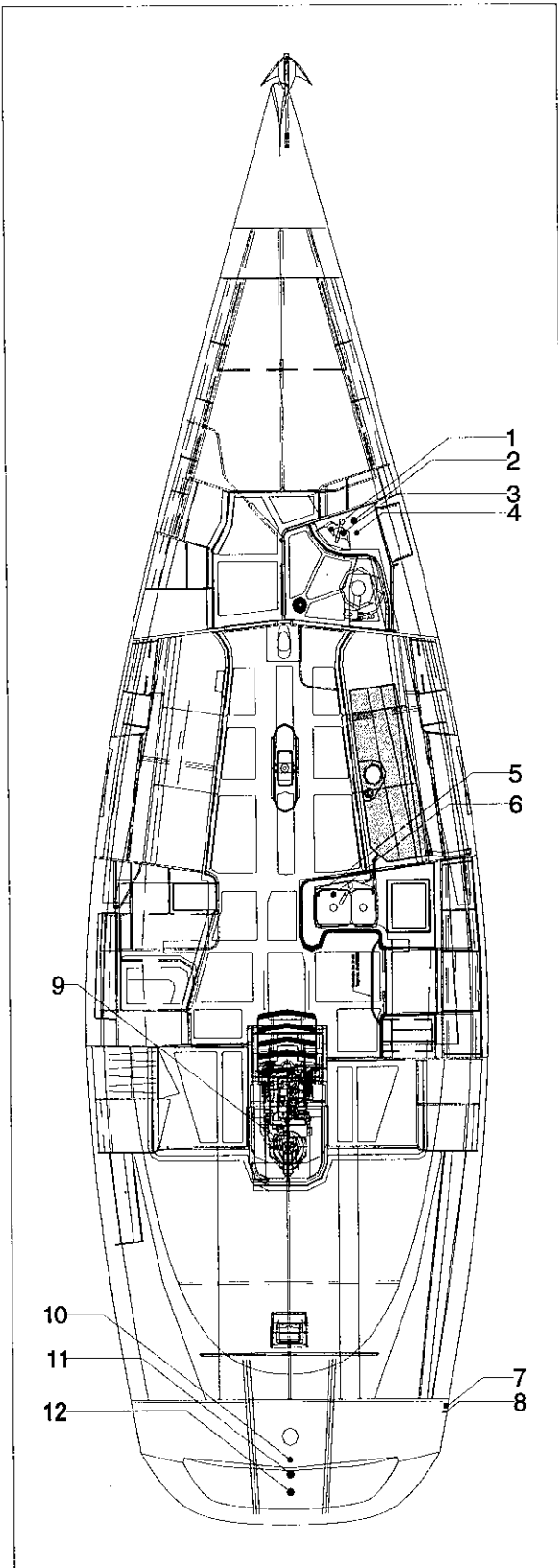

## Seacocks and through hull fittings

1. Fwd toilet sink outlet.
2. Fwd toilet wastewater outlet.
3. Fwd toilet flush water intake.
4. Fwd shower outlet.
5. Seawater intake pantry & deck wash (optional).
6. Pantry sink outlet.
7. Outlet manual sump.
8. Outlet electric sump pump.
9. Built-in engine cooling water inlet in sail-drive.
10. Cockpit drain.
11. Gas drain.
12. Engine exhaust.

In the 2-cabin version (page 18) there are furthermore:

13. Aft toilet sink outlet.
14. Aft toilet flush water intake.
15. Aft toilet shower outlet.
16. Aft toilet wastewater outlet.

### CAUTION

All seacocks must be shut off when not in use to minimize risk of flooding.

### CAUTION

All seacocks and through hull fittings must be inspected once a year, do to function, corrosion and other defects.

X-Yachts recommend to exchange seacocks every 10 years.

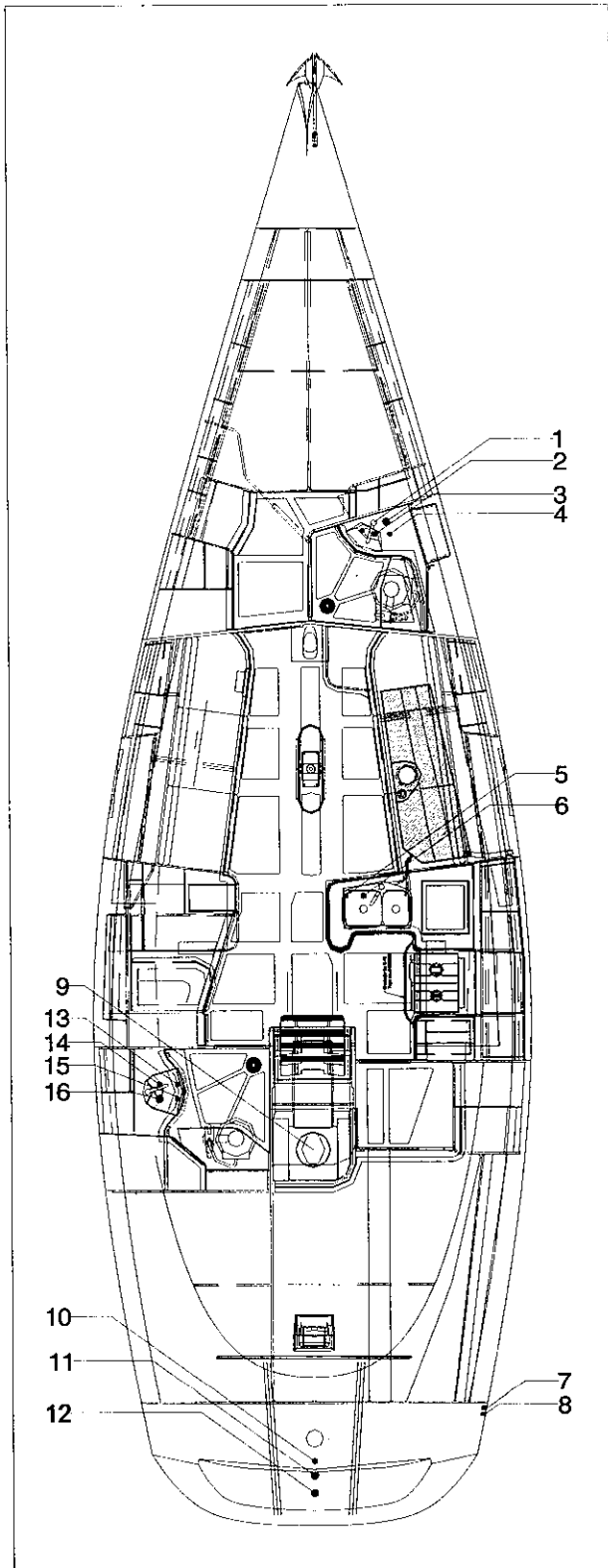

## Seacocks and through hull fittings (2-cabin)

1. Fwd toilet sink outlet.
2. Fwd toilet wastewater outlet.
3. Fwd toilet flush water intake.
4. Fwd shower outlet.
5. Seawater intake pantry & deck wash (optional).
6. Pantry sink outlet.
7. Outlet manual sump.
8. Outlet electric sump pump.
9. Built-in engine cooling water inlet in sail-drive.
10. Cockpit drain.
11. Gas drain.
12. Engine exhaust.
13. Aft toilet sink outlet.
14. Aft toilet flush water intake.
15. Aft toilet shower outlet.
16. Aft toilet wastewater outlet.

### CAUTION

All seacocks must be shut off when not in use to minimize risk of flooding.

### CAUTION

All seacocks must be inspected once a year due to function, corrosion and other defects.

X-Yachts recommend exchanging seacocks every 10 years.

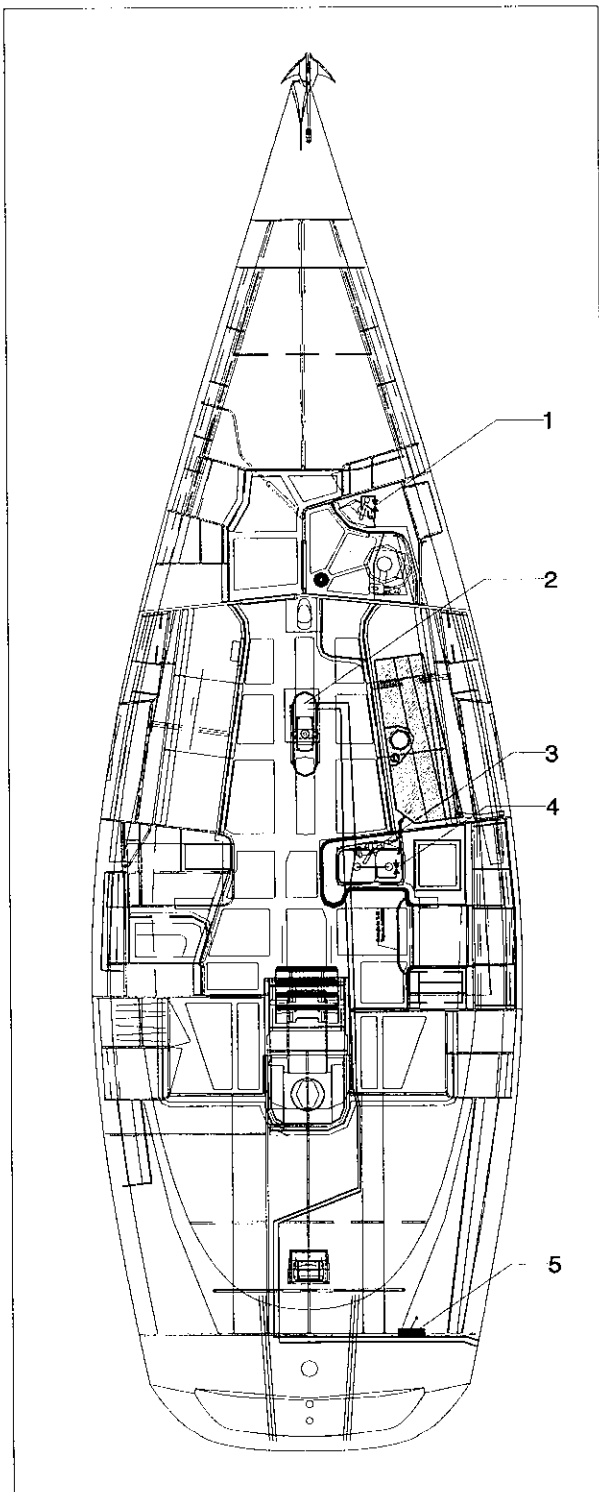

## Draining system

1. Drain from forward toilet sink through seacock.
2. Keel sump.
3. Electric keel sump pump.
4. Drain from pantry sink through seacock.
5. Manual keel sump pump.

The bilge is drained through either an electric keel sump pump or a manual keel sump pump. The electric keel sump pump is placed under the floor in the sink cupboard.

The pump is manually activated at the main electrical panel on the switch labelled "Keel sump pump".

The manual keel sump pump is placed on the aft bulkhead in the cockpit and is operated with the supplied handle. The drain tubes are fitted with a strainer in the keel sump to avoid tramp material in the draining system. Inspect the draining system regularly for clogs etc. to ensure maximum efficiency.

### **Pumping capacities:**

Electric keel sump pump: 30 l/ min. Manual keel sump pump: 42 l/min. At 45 strokes.

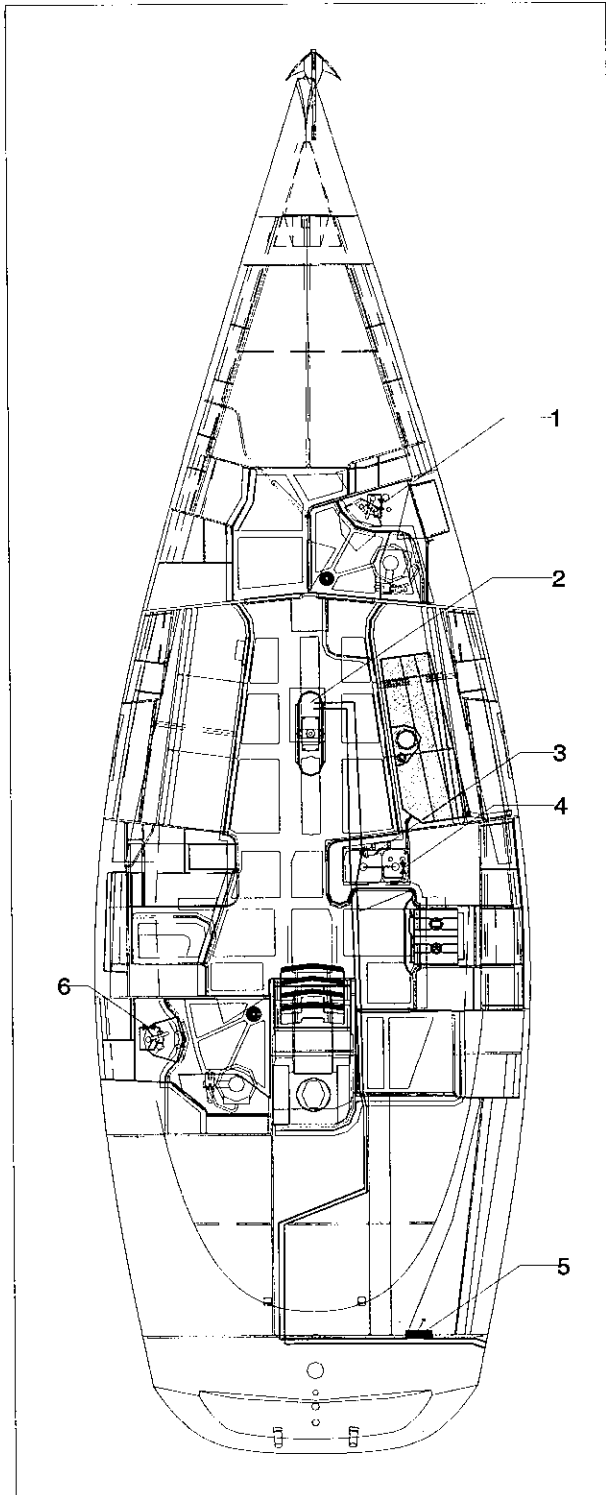

## Draining system (2-cabin)

1. Drain from forward toilet sink through seacock.
2. Keel sump.
3. Electric keel sump pump.
4. Drain from pantry sink through seacock.
5. Manual keel sump pump.
6. Drain from aft toilet sink through seacock.

The bilge is drained through either an electric keel sump pump or a manual keel sump pump. The electric keel sump pump is placed under the floor in the sink cupboard.

The pump is manually activated at the main electrical panel on the switch labelled "Keel sump pump".

The manual keel sump pump is placed on the aft bulkhead in the cockpit and is operated with the supplied handle. The drain tubes are fitted with a strainer in the keel sump to avoid tramp material in the draining system. Inspect the draining system regularly for clogs etc. to ensure maximum efficiency.

### **Pumping capacities:**

Electric keel sump pump: 30 l/ min. Manual keel sump pump: 42 l/min. At 45 strokes.

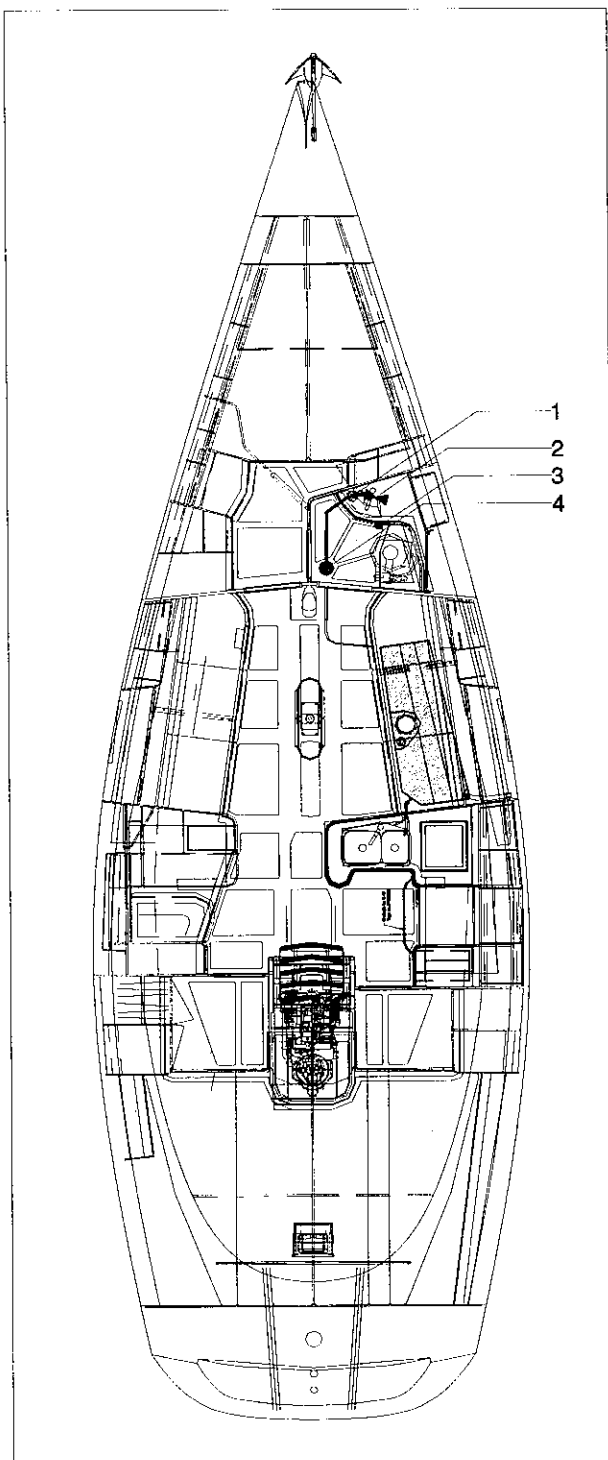

## Shower sump system

1. Forward shower sump.
2. Seacock forward shower sump.
3. Pushbutton forward shower sump pump.
4. Forward shower sump pump.

The shower sump pumps are turned on by means of a pushbutton placed on the cupboard in the toilets.

One main switch serves the pumps and is placed in the electrical panel. The switch is labelled "Shower sump pumps".

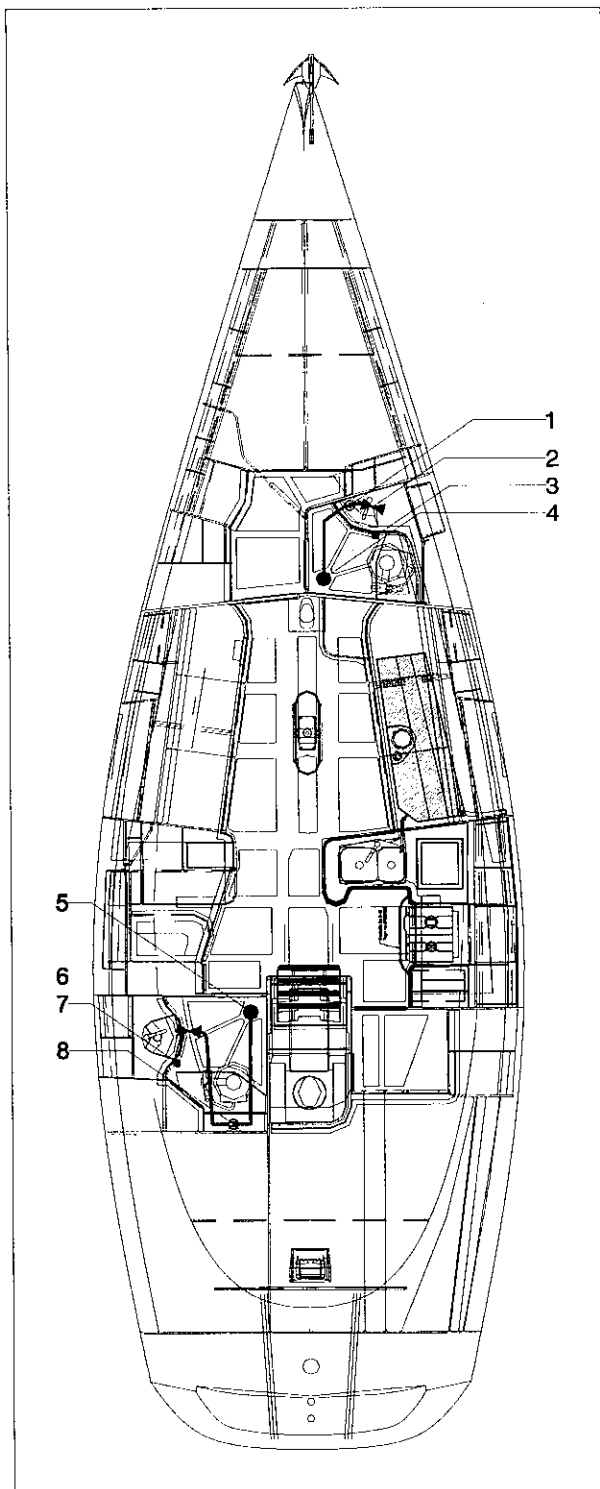

## Shower sump system (2-cabin)

1. Forward shower sump.
2. Seacock forward shower sump.
3. Pushbutton forward shower sump pump.
4. Forward shower sump pump.
5. Aft shower sump.
6. Seacock aft shower sump.
7. Pushbutton aft shower sump pump.
8. Aft shower pump.

The shower sump pumps are turned on by means of a pushbutton placed on the cupboard in the toilets.

One main switch serves both pumps and is placed in the electrical panel.

The switch is labelled "Shower sump pumps".

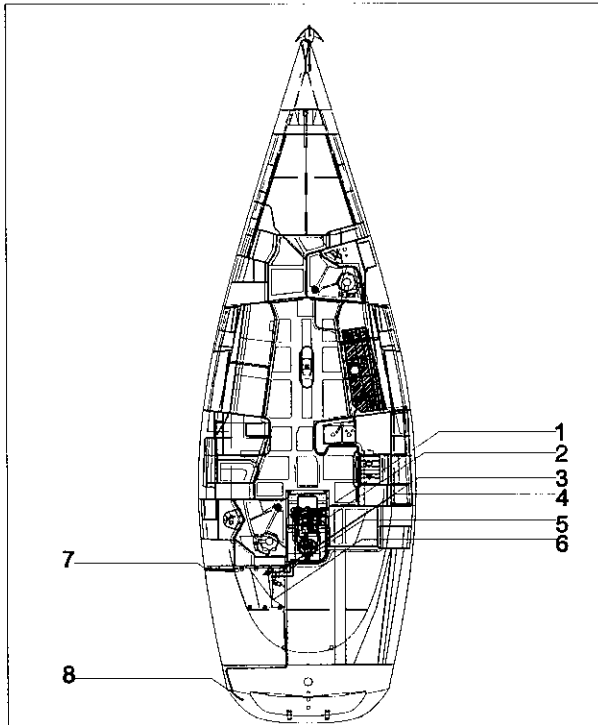

## Fuel system

Detail:

1. Fuel return line.
2. Fuel line.
3. Fuel/water separator.
4. Shut off valve fuel return.
5. Shut off valve fuel fwd.

Overview:

6. Diesel tank.
7. Deck fill cap.
8. Vent line.

The main engine fitted to your craft use standard diesel fuel, which is stored in one main fuel tank. When tanking fuel, close all windows, hatches, etc. adjacent to the deck fill to prevent ingress of fumes into the accommodation.

Avoid overfilling and fill slowly to avoid splashing (not more then 20 l/min).

After filling, close the deck fill cap tight to prevent water from entering the tank. Wash off any spilt fuel immediately with detergent and running water. The tank level is monitored from the tank level meter on the switch panel.

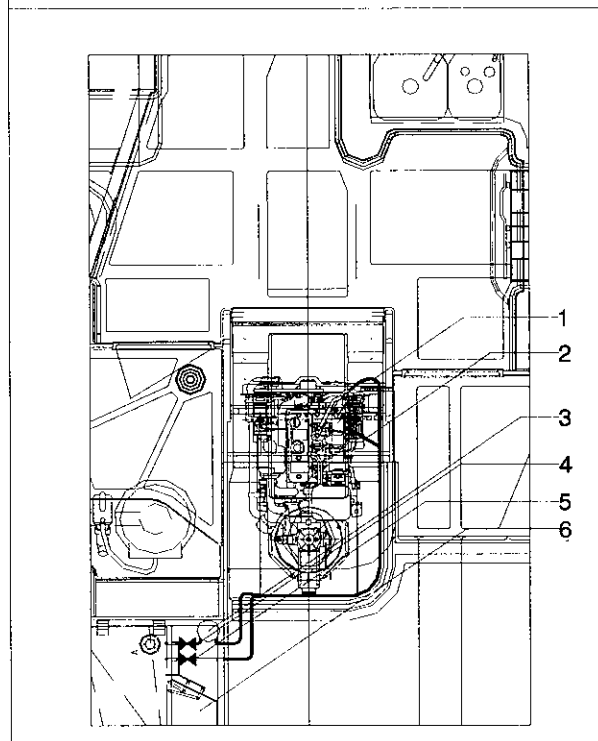

### **DANGER**

In case of fire, shut off all valves on the fuel tank.

Do not smoke when bunkering fuel and do not bunker near naked fire or with engine running.



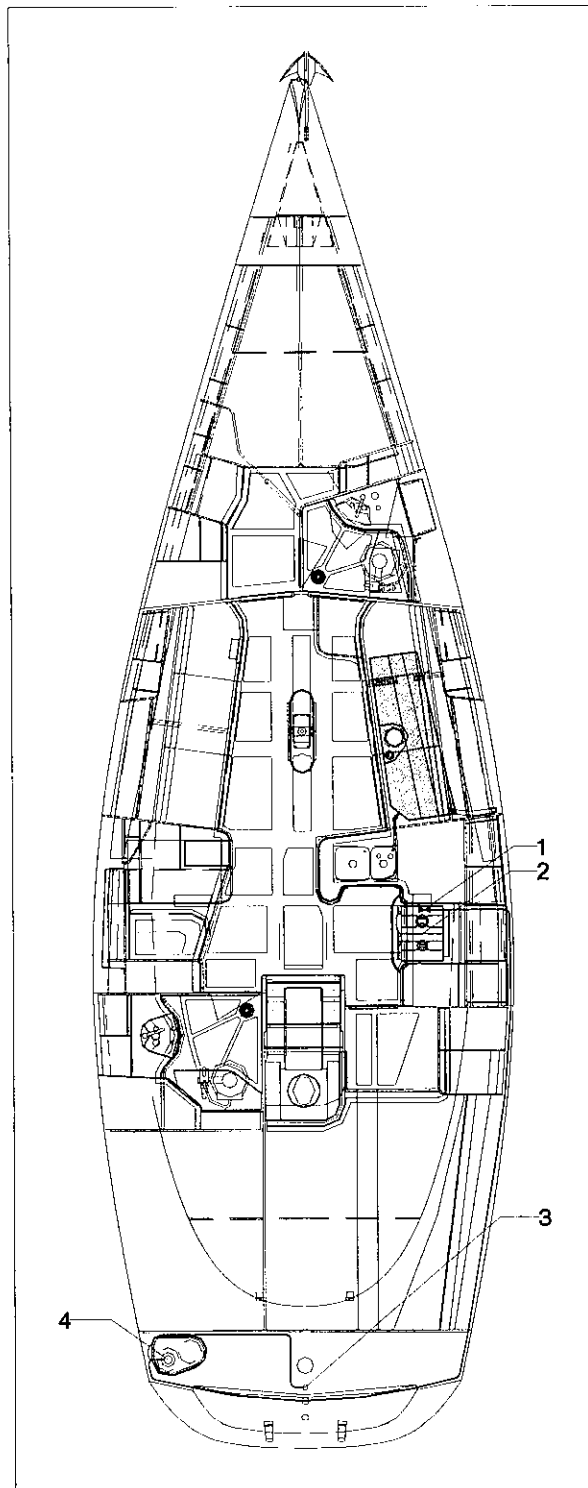

## Gas system

1. Shut off valve and flexible hose.
2. Cooking unit with oven.
3. Outlet gas box drain.
4. Pressure reduction unit and gas bottle (butane, propane mix) ADR class 2.2F, UN 1965.

The gas cylinder(s) is located in the PS aft locker of the cockpit. Ensure that appliances are shut off when applying pressure to the system (opening shut off valve at cylinder). Shut off the valves in the system when appliances are not in use. Never leave appliances burning unattended. Do not obstruct access to gas system components in any way. Always use CE approved cylinders and components.

Keep valves on empty cylinders closed and disconnected. Keep protective covers, caps or plugs in place. Store, reserve or empty cylinders on open deck. Do not use gas box for storage of any other equipment.

Regularly test the gas system for leaks. Shut off the appliance valve and apply pressure. Then check for leaks either using a leak testing device (extra) or soapy water on hoses, connections and piping.

**Specification:**

- Gas type: The gas system is designed for use of a butane, propane mix. ADR class 2.2F, UN 1965 gas only (blue cylinders).
- Operating temp.: The ambient operating temperature of the system is -10 - 40° C.
- Working pressure: The working pressure of the appliances is 30 mbar.
- Capacity: The capacity of the pressure reduction system is max. 1.5 kg/h.

**CAUTION**

Do not use solutions containing ammonia on the gas piping and appliances

We recommend that the gas system is pressure tested by a professional once a year. The test pressure should be five times the working pressure, i.e. 150 mbar.

**DANGER**

Avoid asphyxiation. Provide ventilation through windows and hatches in the cabin when the cooking unit is in use. Do not use for space heating.

In case of gas leak or when replacing gas cylinder(s), ensure that cigarettes and naked flames etc. are extinguished immediately and all electrical systems are switched off.

Never use flame to check for leaks.

**WARNING**

If a gas leak is suspected, the following precautions must be taken:

- Turn off the gas supply.
- Disconnect the gas cylinder(s).
- Open all hatches and port lights to insure maximum air circulation and operate the manual bilge pump.
- Employ a qualified plumber to undertake repairs.

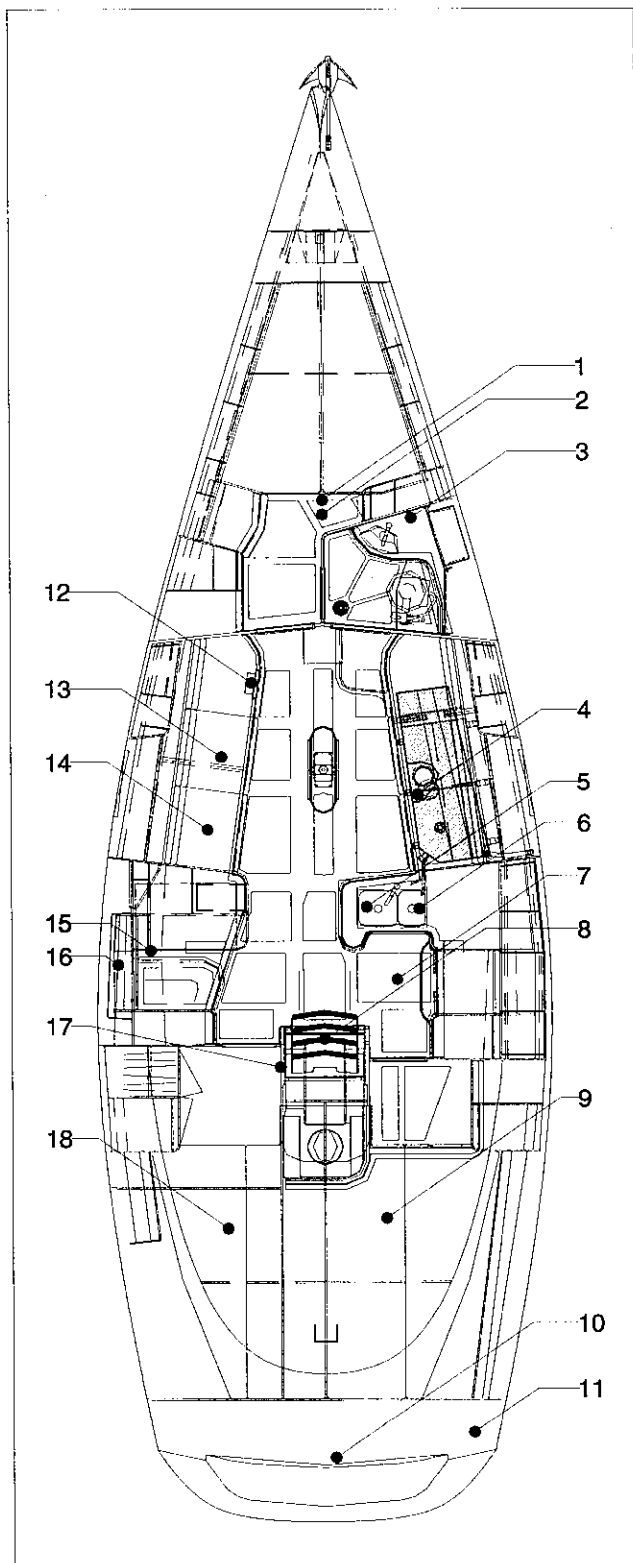

## Electrical installations

1. Log transducer.
2. Echo sounder transducer.
3. Shower sump pump fwd toilet.
4. Fresh water tank gauge.
5. Keel sump pump.
6. Refrigeration compressor.
7. Fresh water pump.
8. Engine start battery.
9. Water heating unit (optional).
10. 230V shore power intake and shore power main fuse.
11. Oil burner.
12. Main fuses.
13. Service batteries.
14. Battery charger.
15. 230V AC main distribution panel.
16. 12V main switchboard.
17. Main switches engine.
18. Fuel level gauge.

The following specification has been made as a general specification for the electrical system on board. Thus, the specification does not describe all technical details. As regards troubleshooting, changes or additional information, we refer to the electrical diagrams and manuals.

The electrical system on board consists of a 12V DC system and a 230V AC system.

The 12V DC system is controlled and monitored from the main switchboard located by the chart table.

The 12V DC panel consists of 20 automatic fuses/switches for light, pumps, navigational equipment etc.

VDO analogue meters for monitoring the actual level of the water and diesel tanks and the voltage of the service- and engine start battery.

## 12V DC system:

### Start battery:

The start battery is located in the SB aft cabin underneath the berth.

The battery is a 12V 55Ah Spiral Cell gel battery, with a cold cranking capacity (CCA) of 750 ampere. The battery is maintenance free.

Main switches for both positive and negative conductor of start battery is located in the front side of the berth. The battery is charged by the alternator fitted on the main engine or by the shore power connected battery charger.

### Service batteries:

Under the PS sofa seat in the main cabin, two or three (depending on extra equipment) 12V 120Ah, C10 maintenance free gel batteries are located.

The service batteries serve the following equipment:

- Interior- and navigational light.
- Pumps: Keel sump pump/ Shower sump pump/ Fresh water pump/ Sea water pump.
- Refrigerator.
- Navigational instruments: VHF, log, echo sounder, wind- and multi instruments, chart plotters etc.
- AM/FM radio.
- Electrical winches/anchor windlass.

The batteries are charged by the alternator fitted on the main engine or by the shore power connected battery charger. Start- and light batteries are separated with a 80-ampere relay.

### Location of main switches:

Main switches for engine battery are located in SB aft cabin. Main fuses for light batteries are located in the saloon in the fwd PS sofa.

### 230V AC:

A CEE shore power plug is mounted at the steering wheel position. 230V AC main fuse is located in the SB aft locker.

Under the chart table are placed an electrical distribution panel with automatic fuse, RDC relay and switches for the following equipment:

- 230V battery charger
- Water heater
- 230V sockets

### Lights:

All down lights are switched on/and off through rocker switches. The light relays are mounted in the 12V main switch panel. All bulkhead lights are switched on/and off directly on the bulkhead light itself.

### Fuel and water tanks:

The boat is equipped with a fuel tank and a fresh water tank.

Both tanks are equipped with a level gauge. The actual storage of these tanks can be read analogous on the electrical board.

## **WARNING**

To minimize shock and fire hazards:

- Turn off craft's shore power connection switch before connecting or disconnecting shore power cable.
- Connect shore power cable to craft inlet before connecting to shore power source.
- Disconnect shore power cable at shore source first.
- Do not allow shore power cable to hang in the water.
- Never work on the electrical installation while the system is energized.
- Never alter or modify the rated current amperage of over current protective devices.
- Never install or replace electrical appliances or devices with components exceeding the rated current amperage of the circuit.

## **CAUTION**

All main switches should be shut off when the boat is left unattended. This does not cause the sump bilge pump to be switched off, as the pump is directly connected to the 12V supply.

Only qualified marine electrical technicians are allowed to modify the electrical installation and the relevant drawings and diagrams.

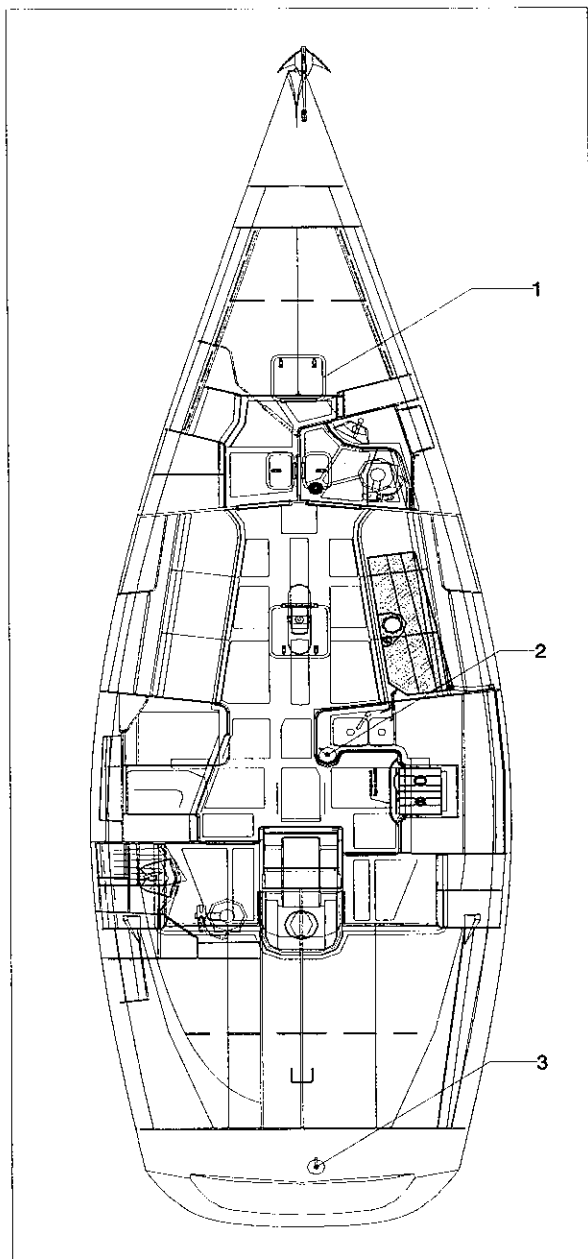

## Fire-extinguishing system

1. Escape hatch.
2. 2 kg 13A89B.
3. 2 kg 13A89B (in cockpit).

This craft, when in service, shall be equipped with portable fire extinguishers of the above extinguishing capacities and in the following locations:

Item #2 is located in the pantry cupboard.

Item #3 is located in the PS cockpit locker.

The fire port to the engine room is located in the SB aft cabin.

It is the responsibility of the craft owner/operator to:

- have fire fighting equipment checked at intervals indicated on the equipment.
- replace fire fighting equipment, if expired or discharged, with devices of identical or greater fire fighting capacity.
- inform members of the crew about the location and operation of fire fighting equipment and the location of escape hatches.
- ensure that fire fighting equipment is readily accessible when the craft is occupied.

Keep the bilges clean and check for fuel and gas vapours at regular intervals.

When replacing parts of the fire fighting installation, only matching components shall be used, bearing the same designation or being equivalent in their technical and fire resistant capabilities.

Do not fit free hanging curtains or other fabrics in the vicinity of or above cookers or other open flame devices.

Combustible material shall not be stowed in the engine space. If non-combustible materials are stowed in the engine space, they shall be secured against falling into machinery and shall cause no obstruction to access in or from the space.

Escape facilities other than the main companionway is the forward hatch and it is identified by the appropriate ISO symbol.

**CAUTION**

**Never**

- obstruct passage ways to exits and hatches.
- obstruct safety controls, e.g. fuel valves, gas valves, switches of the electrical system.
- obstruct portable fire extinguishers stowed in lockers.
- leave the craft unattended when cooking and/or heating appliances are in use.
- use gas lights in the craft.
- modify any of the craft's systems (especially electrical, fuel and gas).
- fill any fuel tank or replace gas bottles when machinery is running or when cooking or heating appliances are in use.
- smoke while handling fuel or gas.

## GENERAL MAINTENANCE

### Hull and deck

#### General maintenance

The general maintenance of the gelcoated surfaces of the boat corresponds to the care that you would normally give your car. We do though recommend using maritime detergent and waxing products.

We recommend that a qualified marine electrician must check the electrical system every second year.

All screw terminals must be tightened and all relays must be checked. If the screw terminals or the contact functions in the relays are corroded or burned, they must be changed.

All the NORPOL® products mentioned below is manufactured by JOTUN POLYMER and should be available at your local boat equipment dealer.

#### Cleaning

Periodic cleaning with soft detergents is necessary to remove normal dirt. This dirt has been caused by regular use together with the environmental pollution sources like carbon, smog etc. A regular washing - when necessary - will avoid the building up of dirt and discolouration. To maintain the sparkling finish of the boat, it is important often to wash down the deck and hull with plenty of fresh water and some boat shampoo to remove salt and grime from the surface. At least three times a season the boat should have an UV-protective wax treatment.

#### CAUTION

Do not use caustic and very alkaline detergents or detergents containing chlorine or ammonium chloride on the gelcoat, as this will cause the surface to fade.

#### Waxing

As gelcoat will start losing its brilliance by constant exposure from the natural environment and pollution sources, it would demand a particular effort to regain the original brilliance and colour.

The gelcoat surfaces need regular maintenance. Especially, the dark colours often need cleaning and waxing.

Wash the exterior gelcoat surfaces of your boat several times each season using a mild detergent and a lot of fresh water in order to remove salt and dirt.

When dry, use a good quality wax for protection against UV rays. We normally use International polish with Teflon and wax sealer with Teflon. The treatment must be repeated again when water does not "pearl" on the surface, sometimes after 2 months in the sun. If the surface has been badly affected from wind and weather, a cleaning and treatment with wax certainly will not re-establish the finish to your satisfaction, and therefore a polish would be necessary.

#### WARNING

Use care in waxing to ensure walkways are not made dangerously slippery.

#### Polish

Use NORPOL® R10 grind and polish paste to remove scratches, discolouration or other seriously damaged surfaces. NORPOL® R10 grind and polish paste can be applied either manually or mechanically. After the weather-beaten surface has been removed, it has to be waxed in order to reinforce the brilliance and colour, and at the same time it gives sealing to the surface that delays discolouration or new dirt accumulation.

#### Removal of discolouring

Discolouring of the gelcoated fibreglass surface may occur, if regular washing and waxing has been neglected. Discoloured areas are really just in the surface. They can be removed easily with soft wet grinding in the affected areas with 800-1,200 grade wet grinding paper for removal of the slight blemishes.

Always grind in one direction only. All areas, including curves, have to be grinded in the same direction. Use plenty of water. After the grinding, the areas have to dry, and one must make sure that all the discolouring has been removed. If not, the procedure has to be repeated. Subsequently, the gelcoat surface has to be polished with NORPOL® R10 by hand or machine.

For machine polish, one has to use a machine with approx. 2,000 rpm. to recreate the brilliance on the grinded surface. Use a soft wool cushion like Oskar's polish disc A880 and apply plenty of NORPOL® R10 with rotatory movements.

Once the polish has been finished, the grind paste has to be washed off with clean water. After the washing, one has to use NORPOL® W50 for removal of possible remnants of NORPOL® R10.

Subsequently, the subject has to be treated with the hard wax NORPOL® W70.

## Damages

The hull and deck of your boat is made of hand laid fibreglass with an outer surface of gelcoat. The gelcoat is in general very resistant against strokes and scratches, but the boat will unavoidably get some minor scratches during its lifetime due to wear. These scratches should be attended to in their early stages.

## Scratches

If the scratch is at the surface of the NORPOL® gelcoat and has not penetrated to the fibreglass, one may use NORPOL® R10 polish paste to "rub it off". The paste has to be applied with a polish disc such as Oskar's A880 by machine or by hand with a wet cloth using a lot of "elbow grease". Probably the scratch will not disappear completely, but it will definitely be less visible.

Repairs of the surface has to be made with NORPOL® filler in the right colour. The mend procedure recommended is as follows:

- The spot for repair has to be degreased with acetone to remove all signs of wax and oil.
- Carefully mix 1 tablespoonful of NORPOL® stopping with two or three drops of catalyst on a piece of cardboard.
- Apply the mixture on hole, broken fragment or groove with a single shaped razor blade fitting to the surface and contour of the area to be repaired. It is better to apply just a little more mend mixture than needed to avoid having to fill up the damaged part again.
- Let it harden well and truly in one to two days and nights.
- Use 800-1,200 grade wet grinding paper on a grind block. Water grind the mended down to level.
- Finish with NORPOL® R10 polish paste.

If damage goes through to the laminate or it covers a large area of the hull or deck, it should be repaired by a professional.

It is good practice to use fabric fender protectors to avoid scratching the freeboard.

### CAUTION

If stress cracks occur or delaminating is suspected, contact a GRP laminate specialist immediately. Rubbing the hull with abrasive compounds or sandpaper removes the gelcoat. As this is only a thin layer, great care should be taken. If in doubt, consult a professional.

## Bottom treatment

If the boat is delivered with the bottom treatment from X-Yachts, 3 coats of epoxy barrier and 2 coats of antifouling are applied to the degreased and sanded gelcoat bottom.

The epoxy barrier is applied to seal the hull and to reduce the risk of gelcoat blistering. It is therefore of vital importance that this barrier is kept intact.

Antifouling should be checked on a regular basis and replaced at least once a year.

### CAUTION

Some types of antifouling are incompatible, so it is advisable to keep a record of used antifouling and to consult a professional, if you want to change antifouling type.

Be careful not to cover zinc anodes, grounding plates or transducers.

## Cathodic protection

The zinc anodes mounted on the hull and saildrive or propeller shaft must be replaced when approx. 2/3 eroded in order to maintain cathodic protection.

### WARNING

Failure to insure cathodic protection may result in leakage and serious damage to metal parts.

### CAUTION

X-Yachts recommend doing maintenance of the vacuum valve regularly in accordance with the following instruction.

Regularly remove salt, rust and dirt from all valve components and from the valve housing by rinsing out with clean water. Remove the cap (1) in order to take the valve out of the housing. Spray the valve components with a Teflon spray (silicon oil) before refitting.

Check the valve operation (vacuum suction on the air vent pipe connection) and the cap sealing before returning to use.

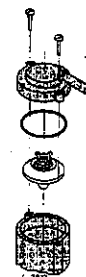



## Deck hardware and rigging

### Deck gear and hardware

Wash all deck gear and hardware in fresh water and soap and inspect the deck gear for defects and damages regularly. Lubricate all moving parts with grease or teflon spray in accordance with the specific manual. A glass cleaner is usually safe for stainless. Remove rust spots as soon as possible with a brass, silver or chrome cleaner. Never use an abrasive like sandpaper or steel wool on stainless.

### Maintenance of Teak Deck

It is important to maintain the teak deck by rinsing with water and not to use any equipment that will wear out the teak and seams.

By rinsing with saltwater, you will leave a thin layer of salt, which absorbs moisture and therefore counteract drying up of the wood, mould growth and alga. Deck hardware should, however, be washed with freshwater.

It is also very important to check the seams and repair loose damages in the seams, as water under the teak deck can loosen the teak from the GRP. The seams along the cabin and around the chain plates are especially exposed.

New caulking, adhesive and primer can be ordered at X-Yachts A/S.

### Running rigging

Check regularly all sheets, halyards, hauls etc. for wear and damages that reduce their strength and replace them if necessary.

### Standing rigging

Check regularly all shackles, pins, blocks, rigging screws etc. If they show any signs of cracking or deformities, they should be replaced. Check also that all of the rigging is properly fastened and in the right positions. Wash rigging close to the deck regularly in fresh water.

#### **WARNING**

Do not raise any halyards or tension the rigging before deck tie rods are attached to the mast collar and the mast. Failure to do this could result in severe damage to the deck structure.

### Sails

Check regularly for wear and tear, and turn them in to your sail maker if necessary. If they need cleaning, ask your sail maker for advice or let the sail maker do the job. Always ensure that your sails are as dry as possible before packing and storing them.

### Mast, boom and spinnaker pole

Wash the spars and fittings with fresh water and soap to remove salt and grime regularly. The anodized parts can be polished, if required, to protect them from staining.

Make sure that all sharp edges are fully taped for protection. Lubricate fittings as required. Secure all rigging away from the surface of the spars as there could be corrosion between the different materials or chafe caused by the wind. Check regularly for sign of stress cracks around joins and halyard exits.

It will be necessary at times to work aloft to carry out maintenance. If you are uncomfortable aloft, get an experienced crewmember or a professional to undertake the work.

#### **DANGER**

Mast and other rigging components conduct electricity. Contact with overhead electrical wires could be fatal!

Please exercise extreme caution when rigging or sailing.

#### **WARNING**

To ensure safety follow this procedure when preparing and carrying out a personnel hoist.

- 1) Procure and check the necessary equipment, starting with the flake and halyard. The halyard must be in good condition particularly around the shackle. A second halyard must always be connected for safety. Never rely on snap shackles as these can snag and release.
- 2) Use a deep bag for your tools, remembering that any tool dropped may injure persons below or do damage to the deck. A messenger line can be used to raise and lower tools.
- 3) Use an experienced assistant who is familiar with winches. Climb with your feet and hands as your assistant winches with at least three turns on the drum. Make sure that your assistant fastens the halyard end to a secure cleat or ties it to the winch. Tie yourself to the mast with a short line to lock yourself in position.
- 4) When lowering, make sure that the halyard tail is clear and ease the halyard slowly around the winch. The assistant must ensure good foothold and steady grip on the halyard at all times.

Personnel hoist is safest if carried out in harbour under calm wind and sea conditions with proper distance to other masts and riggings.

## Canvases

### Sprayhood and cockpit covers

The canvas consists of 100% dyed in polyacryl (Dralon Dorcolor), coated with polyurethane and impregnated with Baygard. Sprayhoods and cockpit covers endure ordinary washing at max. 30°C, but should not be dry-cleaned nor washed down with high pressure.

Sprayhoods or cockpit covers should only be machine or laundry washed if extremely dirty, such washing being very hard on the canvas. The canvas is not guaranteed waterproof if machine-washed. Washing is recommended at least once a season in order to avoid mould. The cover should be soaked for 6-8 hours in a mild detergent and thereafter rinsed with a brush while unfolded on floor or a table or mounted on the craft - if possible after rainy weather when the canvas is already soaked. The canvas is mould proof from the factory, but should be re-impregnated after washing. A silicosis-impregnation for textiles is recommended.

Sprayhoods or cockpit covers must be impregnated while mounted on the craft. The canvas must be clean and absolutely dry before treatment. The impregnator is applied with a soft brush, normally only on the outer side. After treatment, the canvas should not be folded if still wet. The impregnation is only effective if the material is absolutely dry. When treated with impregnation, the canvas is waterproof and protected against mould.

Mould arises due to condensation of humidity. Condensation can be reduced considerably if proper ventilation is provided.

## Interior

### Lacquered wooden surfaces

When cleaning the wooden surfaces of the interior, use a soft rag wetted in water and dishwashing detergent.

Rubbing the area lightly with 240-grade sandpaper should repair scratches. Apply a thick layer of lacquer and let it dry. Rub the area lightly with 240-grade sandpaper again before applying the final layer of lacquer.

If the damage comes from an impact to the surface and a permanent compression mark shows, the lacquer should be rubbed off with sandpaper and the naked wood wetted by water. Use an electrical iron to carefully apply heat to the surface through a paper coffee filter bag until the compression mark "grows out" and disappears. When the surface is dry, proceed with the same lacquer procedure as described for repairing scratches.

### Lacquer products applied from X-Yachts:

Floors:	lacquer:	SUPER DUR GL 40, 1416
	catalyst:	Super Dur catalyst, 1406
	thinner:	Super Dur thinner, 1112
Interior:	lacquer:	DANTOP Extra GL 25, 8462
	catalyst:	1399
	thinner:	NICO, 1183

### All lacquer products are supplied by:

**A/S HYGÆA**  
Gasværksvej 30, Box 582, 9100 Aalborg Denmark  
Phone: +45 98 13 31 00

### **CAUTION**

Extensive heat may result in dark areas on the wooden surface. If you are unfamiliar with woodwork or in doubt about a specific task, please consult or employ a professional before undertaking the repair.

When repairing lacquered surfaces, the used lacquer products should be similar and compatible to the product applied from X-Yachts.

## LAYING-UP AND WINTER STORAGE

### Lifting

Lifting of the craft can be done either with slings or by single-point lift.

#### Lifting with slings:

Position of aft sling should be 850 - 1050 mm forward of stanchion No 1 (counting from the aft most stanchion and forward). Position of forward sling should be in the area of 250 - 450 mm fwd of stanchion No 2 (counting from the foremost stanchion and aft).

#### Single-point lift:

Single-point lift is carried out by using the lifting strap and shackle (extra).

#### Lifting procedure:

1. Remove floor plate between pantry and nav. station and both inside and outside caps on lifting hole in the cabin roof.
2. Attach shackle to the lifting bracket of the steel floor frame.
3. Check lifting strap thoroughly for possible injuries. If there is any sign of weakness, do not use the lifting strap.
4. Lead the lifting strap through the hole in the cabin roof. Ensure that the lifting strap is not twisted or kinks in any way.
5. Attach crane shackle to the lifting strap.
6. Attach control lines in forward and aft mooring cleats.

#### **CAUTION**

Always ensure that lifting material meets appropriate safety standards and is not damaged in any way.

Always ensure that slings are clear of rudder, keel, sail drive, transducers etc.

### Cradle

A foldable galvanized steel cradle is available from the yard as optional equipment. We recommend that this cradle is used for winter storage of the craft.

Always ensure that the cradle is placed on solid and horizontally aligned ground. Also ensure that the craft is safe against likely wind direction and protected against vandals.

If the craft is stored under open sky, it should be covered. Ensure that the cover is secured in such a manner that it doesn't catch wind and damages the craft due to chafing.

## Hull and deck

### Cleaning

Right after the boat is lifted out of the water, wash off the bottom with a high-pressure cleaner or a brush to avoid possible fouling from drying in and fix itself more firmly to the bottom.

Wash down the deck and hull with plenty of fresh and preferably warm water together with some boat shampoo, and give the boat an UV-protective wax treatment.

### CAUTION

Do not use detergent containing chlorine or ammonium chloride on the gelcoat, as this will cause the surface to fade.

## General winterization

- Ensure the craft is adequately ventilated. Open all lockers and cabin doors to allow air to circulate.
- Arrange heating if possible for periods of extreme cold.
- Remove all cushions for cleaning and storage in a dry and preferably heated place.
- Remove all portable equipment liable to corrode from craft.
- Drain tanks and piping to avoid damages from frost swells. Except for the fuel tank, which should be filled completely to reduce risk of damages due to corrosion.
- Remove batteries for cleaning, charging and storage.
- Refer to engine manual for proper winterisation of engine.
- Remove sails for storage in a dry place. If necessary have them cleaned, checked and repaired by a sailmaker.
- Clean and check all running rigging. Replace damaged or perished items.
- Check all standing rigging for possible damages and excessive wear. Replace items as needed.
- Check mast fittings including tracks, sheaves, spreaders, electrical cables and gear. Pay special attention to items that are difficult to check when the mast is on the craft.
- Dismount all deck blocks etc. and wash them in warm fresh water. Check for damages and replace if needed. Remount again just before launching.
- Remove all sheets and mooring lines etc. and wash them in fresh water. Ensure they are absolutely dry before storing them.
- Remove old or loose antifouling and apply a new coat. Be sure that the new coat is of same type or at least a compatible type of antifouling. We encourage you to keep a log of these things.

## **APPENDIX**

- **Deck layout**
- **Anchoring arrangements**
- **Profile/Sail plan**
- **Propulsion arrangement**
- **Electrical installation diagrams**

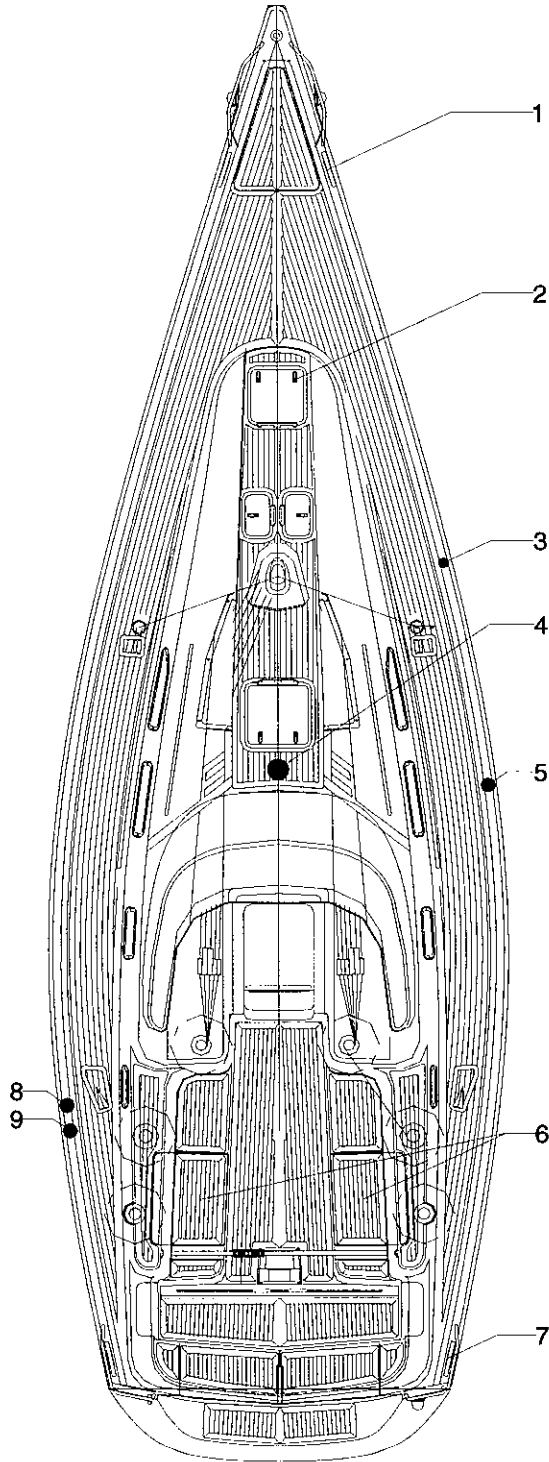

## Deck layout

1. Fwd mooring arr.
2. Escape hatch.
3. Pump out deck fitting fwd holding tank.
4. Single-point lifting strap.
5. Fill cap for freshwater.
6. Recommended location of life raft.
7. Aft mooring arr.
8. Pump out deck fitting aft holding tank.
9. Fill cap for diesel.

## Anchoring arrangements

It is important to take the load off the anchor bow fitting that carries the anchor when anchoring.

When you are anchoring, a heavy torque is created in the above-mentioned fitting due to the distance from the attachment to stretch point.

Under unfortunate circumstances that torque will bend the bow fitting when anchoring, then take the rope delivered with the anchor, run it through the stainless steel eye on the anchor bow fitting and fasten it to the anchor chain by means of a shackle. Fasten the rope to the craft's mooring cleat and give slack to the anchor chain until the rope takes the entire load.

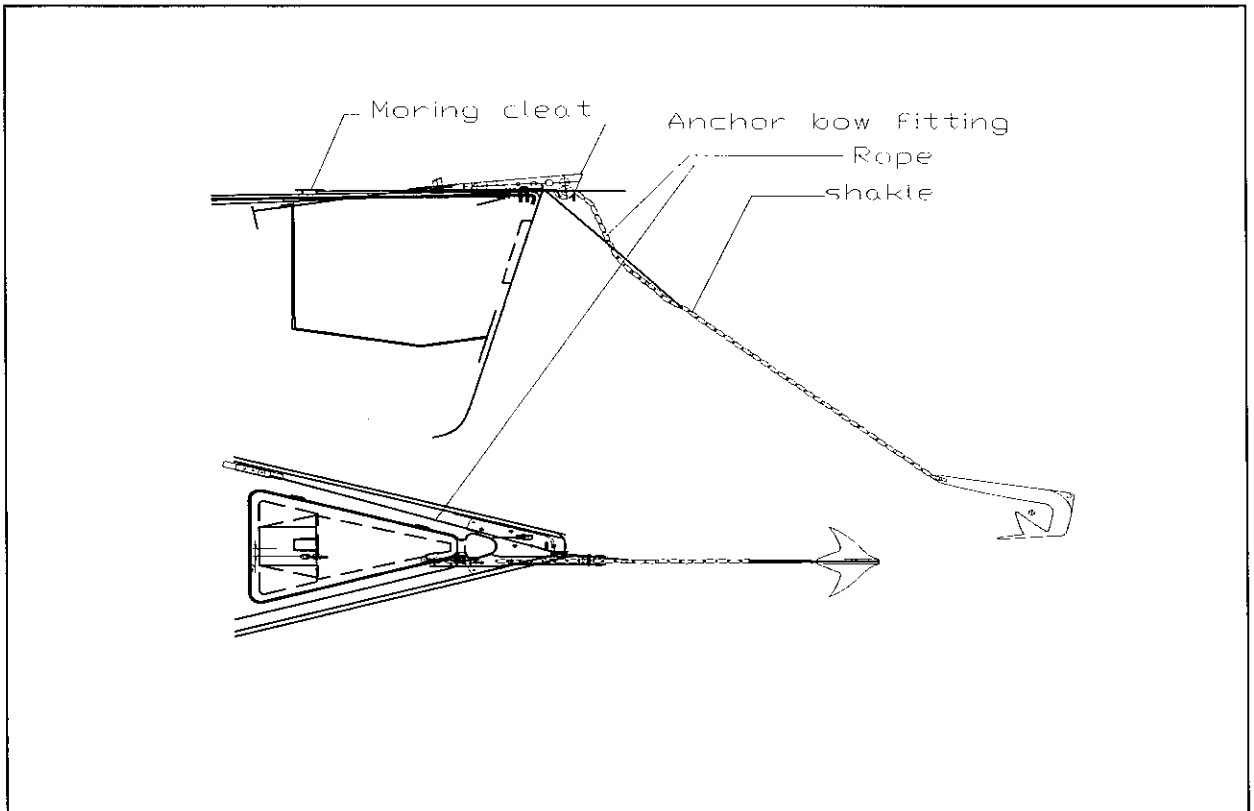

**Profile/sail plan**

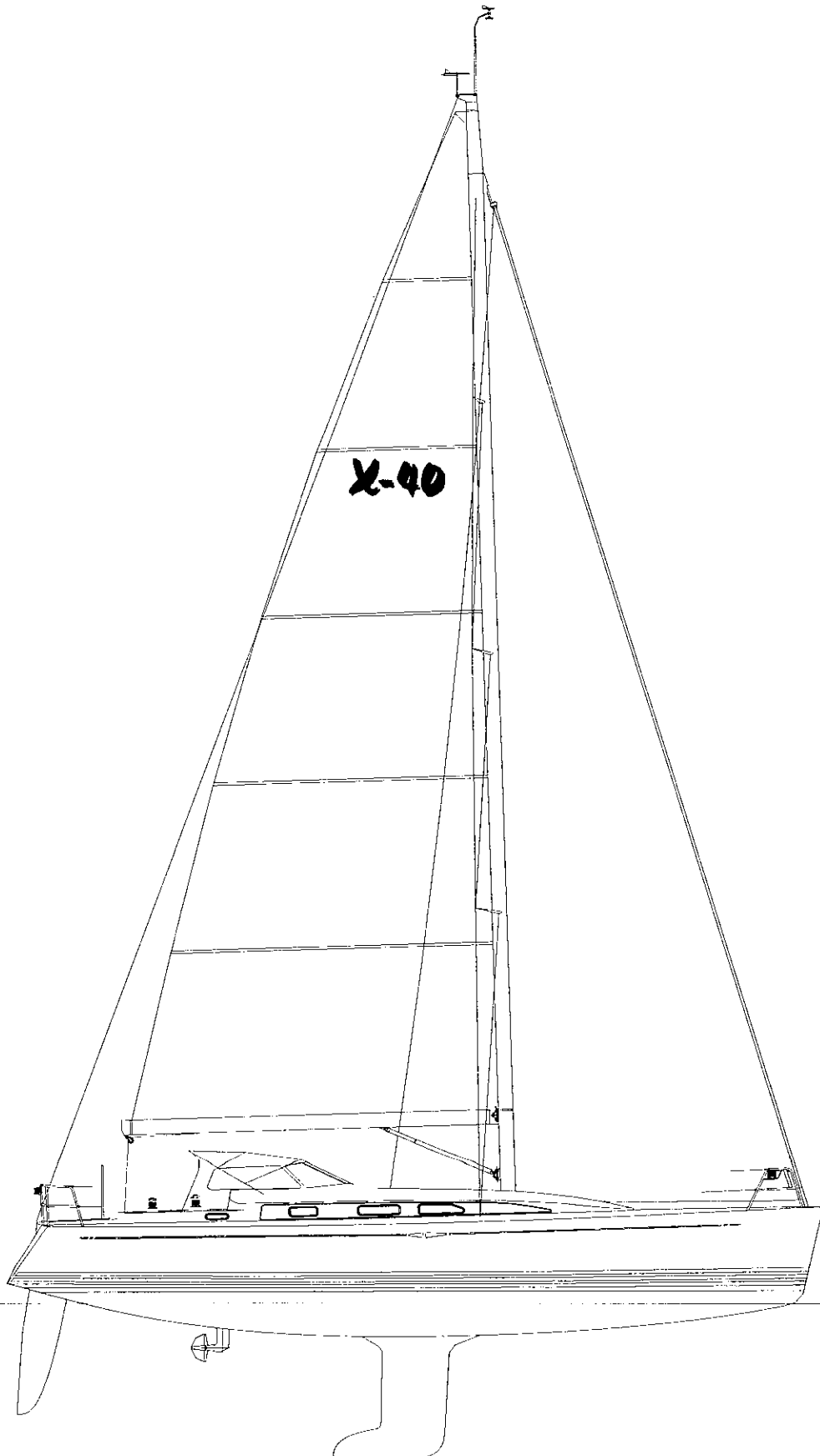



## Propulsion arrangement

### Installation and operating instructions

These instructions cover installation and operation of all Flex-O-Fold Propellers unless they have been modified by Flex-O-Fold in which case a supplement will be provided.

(Exploded diagrams of 2-blade/shaft, 2-blade/SD, 3-blade/shaft, 3-blade/SD)

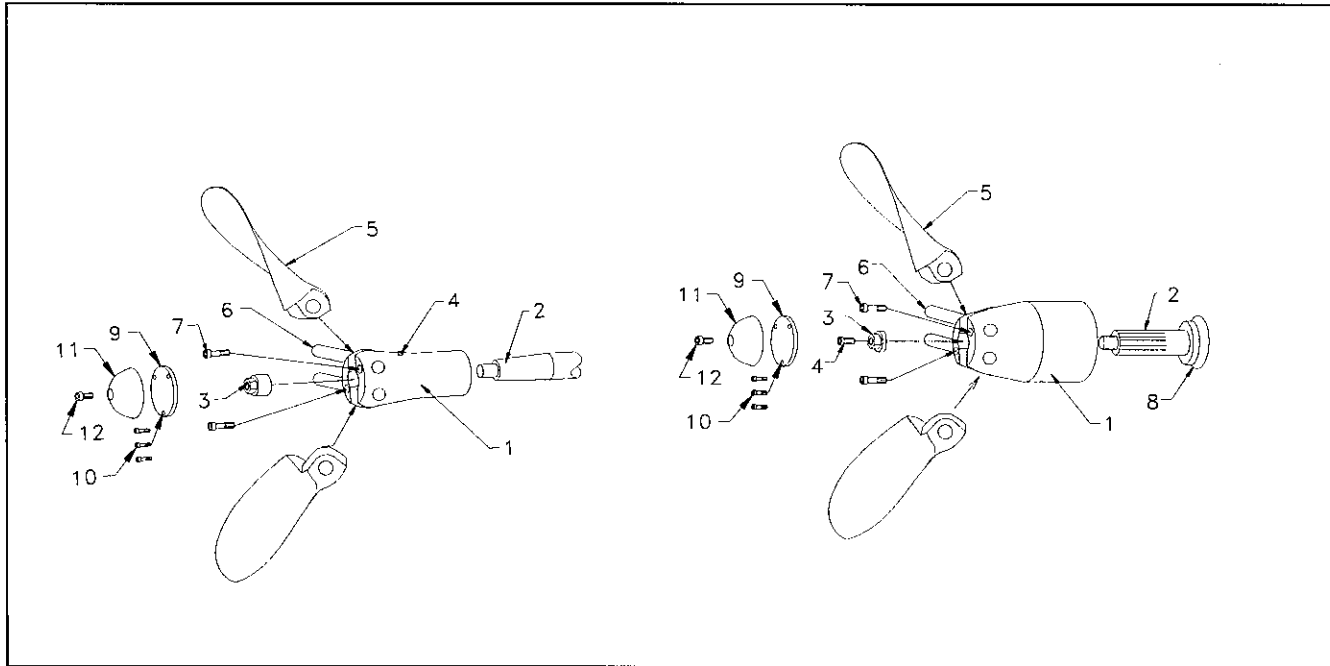

#### Parts list:

- |                                    |  |
|------------------------------------|--|
| <b>1. Hub</b>                      | <b>2. Shaft (not supplied)</b>           |
| <b>3. Shaft nut</b>                | <b>4. Nut locking screw (shaft only)</b> |
| <b>5. Blades</b>                   | <b>6. Pivot pins</b>                     |
| <b>7. Pivot pin locking screws</b> | <b>8. Spacer (not supplied)</b>          |
| <b>9. Cover plate*</b>             | <b>10. Cover plate screws*</b>           |
| <b>11. Zinc anode*</b>             | <b>12. Zinc screw*</b>                   |

\* Used with 3-blade only

Thread locker: Thread locker (e.g. Loctite) is required on most screws in installation. A small tube of semi-permanent thread locker is supplied with each hub. There is also an underwater thread locker pre-applied on most of the screws (red material on threads). Those with the pre-applied thread locker can be installed out of or under water. The thread locker in the tube can only be used out of the water where it can air-cure.

**Installation of Shaft Hub (if using Sail Drive Hub, see below):**

1. Remove key from shaft keyway.
2. Gently slide hub (1) over tapered portion of shaft (2). Mark shaft at forward-most point of advance of hub. If installing under water, use a rubber band to mark shaft.
3. Remove hub and replace key in shaft keyway.
4. Remount hub over key, making sure key does not ride up any radius in the keyway. When mounted, hub should reach or slide over mark placed on shaft in step 2. This will insure key is not interfering with proper fitting of hub on taper. If hub does not reach mark, remove hub and file key as much as necessary to produce proper fit.
5. Screw on shaft nut (3) provided and tighten very tight.
6. Place small amount of thread locker on threads of Allen head locking screw (4) and screw in tight in tapped hole on side of hub. This will lock shaft nut in place.

**Installation of Sail Drive Hub (if using Shaft Hub, see above):**

1. Check to see that spacer washer (8), which is supplied by engine manufacturer, is installed. Propeller will not function properly without spacer washer.
2. Slide hub over splines on shaft.
3. Screw on shaft nut provided and tighten to at least 5 N\*m (36 ft\*lb).
4. Place a small amount of thread locker on threads of 8 mm socket head cap screw (4) and screw in very tight.

**Installation of blades, 2 and 3-blade:**

1. Align blades (5) with hub jaws and insert pivot pins (6). Be sure notch in pin allows the pivot pin locking screw (7) to be inserted.
2. Apply thread locker to threads in pivot pin locking screws and insert. Tighten up hard.
3. Adding some waterproof grease will improve opening and closing in the air as well as underwater. Work blades open and folded to insure ease of operation.
4. (3-BLADE ONLY) Mount cover plate (9) and zinc (11) with socket-head cap screws provided after having applied thread locker to threads.

**Operating instructions:**

1. Shift gears at idling RPMs only.
2. Check that the propeller functions in both forward and reverse before each voyage.
3. When sailing, stop engine and put in reverse to prevent propeller from turning.
4. Stop engine immediately if any strange sounds or vibrations are noticed coming from propeller.
5. Do not operate propeller when close to people or animals in the water.
6. When handling assembled propeller, avoid being pinched by opening or closing blades.

---

**Electrical installation diagrams**

## X-40 Classic

	Page
1 Service batt., Start batt., Main fuses, Main dist.	1
2 Spare	2
3 Cabin lights 1	3
4 Cabin lights 1	4
5 Cabin lights 2	5
6 Cabin lights 2,	6
7 Cabin lights 3	7
8 Cabin lights 3	8
9 Night-/Navigation-/Anchor-/windex-/Tri colour- and Deck flood light	9
10 Compass- /Steaminglight/Radio Cd stereo/Instruments/autopilot/Radar/plotter/VHF	10
11 Refrigerator/freezer/Winches/bowthruster/Fresh water-/Sea water pump/Deck wash pump	11
12 Shower sump pumps/Keel sump pump	12
13 Level gauges black water tanks, Level 1	13
14 Tanklevel Fuel 1 and Fuel 2	14
15 Tanklevel Water 1 and Water 2/ Voltmeter	15
16 12V Socket/ Autopilot/NMEA data plug and NMEA bridge	16
17 Heater/ Dir+ Radio Cd stereo/Gas detector/Gas switch	17
18 Engine room ventilation	18
19 Anchor winch Lofrans	19
20 Spare (Electrical winches)	20
21 230V AC shore power inlet and shore power main fuse	30
22 230V AC Dist. box (Only shore power)	31



**X-Yachts**  
WORLD CLASS SINCE 1979

Project: X-40 Classic

Page: 11

K-number:

Last page: 31

Revision: 11-01-2006

Pages in total: 23

Service batt., Start batt., Main fuses, Main dist.

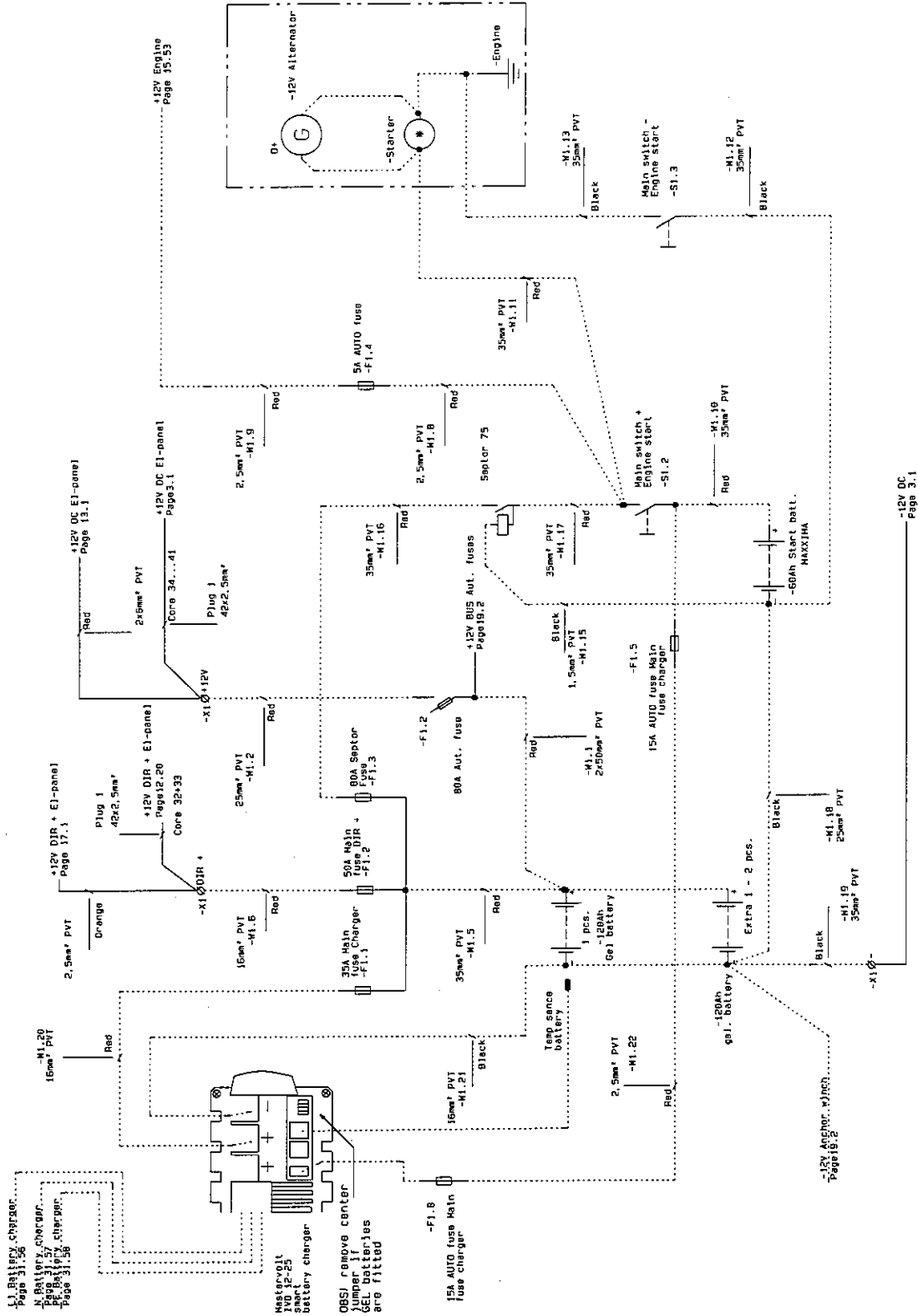

1 2 3 4 5 6 7 8 9 10 11 12 13 14 15 16 17 18 19 20 21 22 23 24 25 26 27 28 29 30 31 32 33 34 35 36 37 38 39 40 41 42 43 44 45 46 47 48 49 50 51 52 53 54 55 56 57 58 59 60 61 62 63 64 65 66 67 68 69 70 71



Fjordgøvej 21  
 5100 Haderslev  
 Phone: +45 74 52 10 22  
 Mail: info@x-yachts.com

Boattype: X-40 Classic  
 Designer: John Morsing  
 Revision: 11.01.06

Date: 20-03-2007  
 Time: 08:11:27  
 Page: 1

Spare

1 2 3 4 5 6 7 8 9 10 11 12 13 14 15 16 17 18 19 20 21 22 23 24 25 26 27 28 29 30 31 32 33 34 35 36 37 38 39 40 41 42 43 44 45 46 47 48 49 50 51 52 53 54 55 56 57 58 59 60 61 62 63 64 65 66 67 68 69 70 71



Fjordsgervej 21  
6100 Haderslev Denmark  
Phone: +45 74 52 10 22  
Mail: info@x-yachts.com

Boattype: X-40 Classic

Designer: John Morsing

Revision: 11.01.06

Date: 20-03-2007

Time: 08:11:27

Page: 2

Cabin lights 1

412V DC EI-panel  
Page 1.39

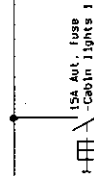

42x2.5mm²  
-Plug 1 (Panel)  
Core 1+2

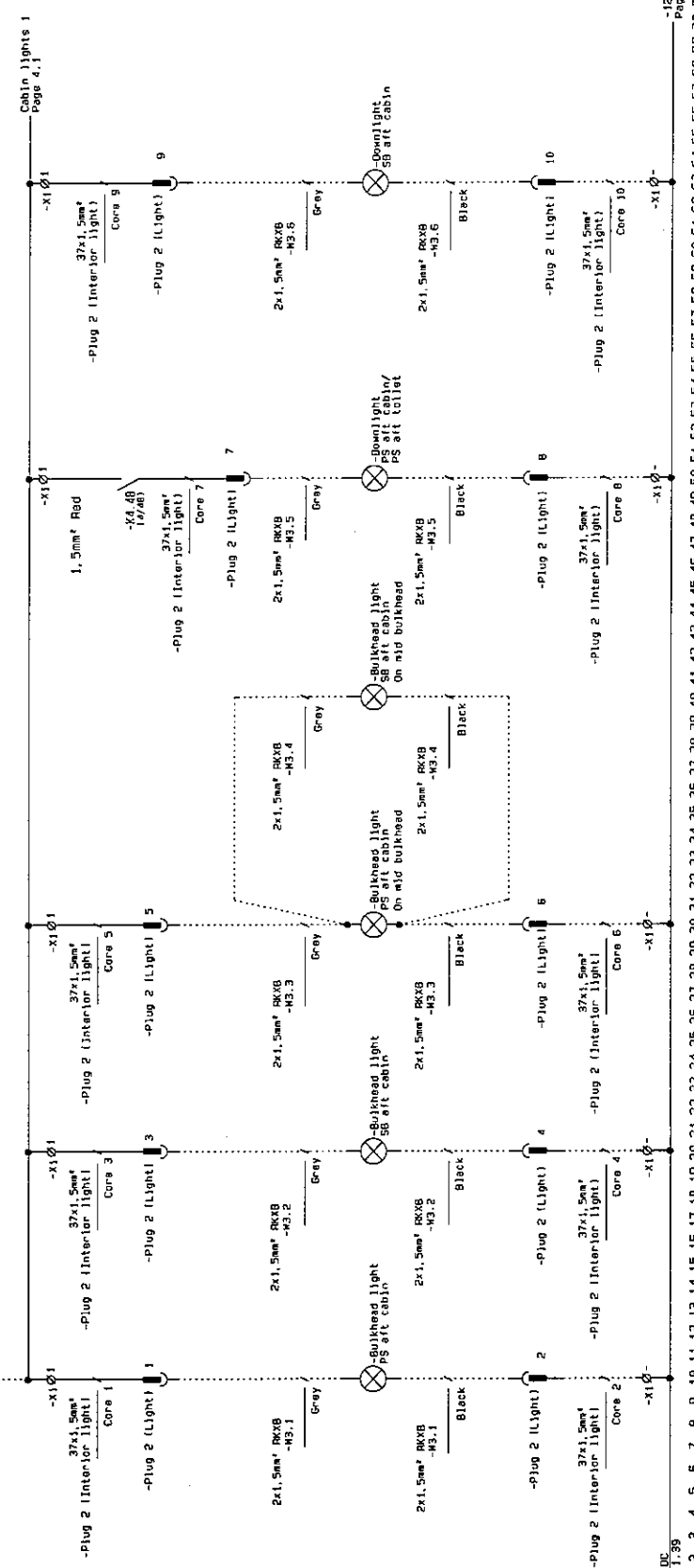
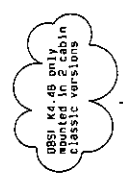

Fjordsgørvej 21  
5100 Haderslev  
Phone: +45 74 52 10 22  
Mail: info@x-yachts.com

Boattype: X-40 Classic  
Designer: John Morsing  
Revision: 11.01.06

Date: 20-03-2007  
Time: 08:11:27  
Page: 3

Cabin lights 1

OBS! Only in X-40 Classic versions

OBS! Only in X-40 Classic versions

Cabin lights 1  
Page 3/66

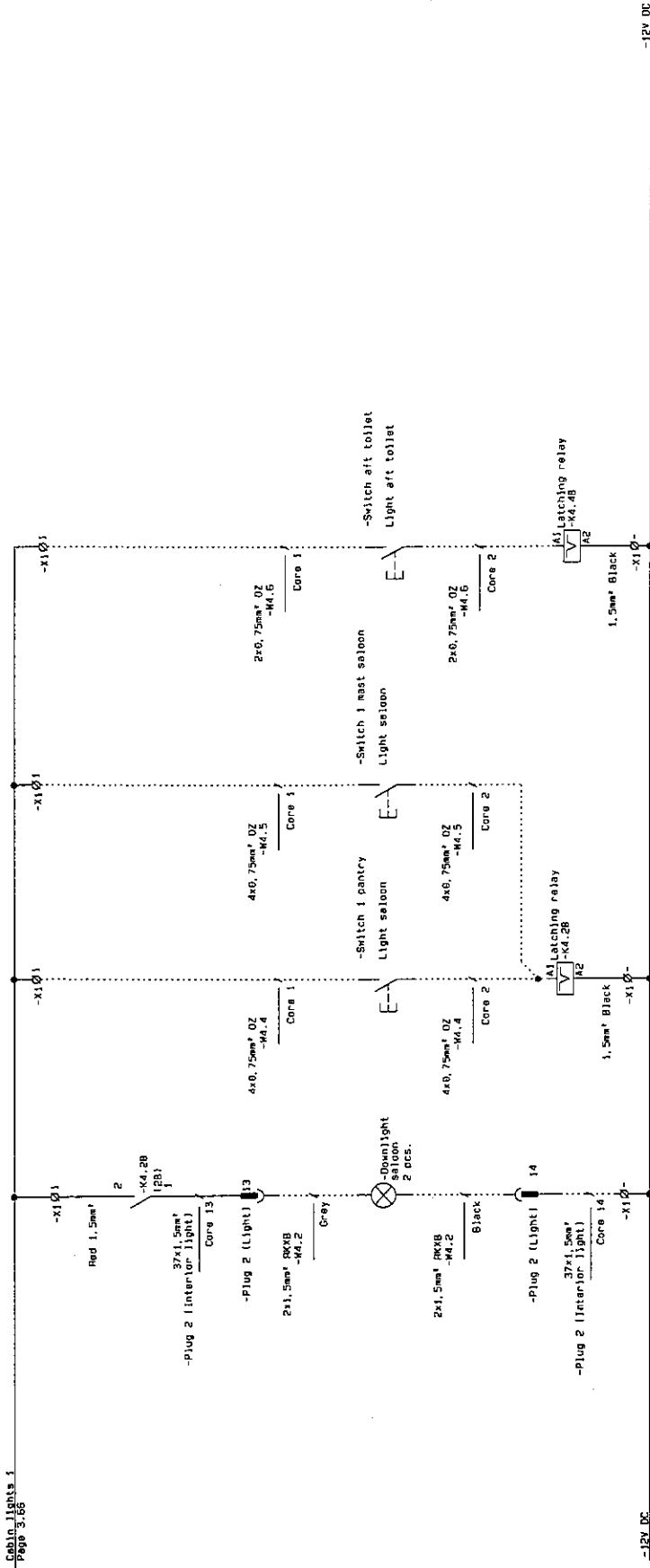

-12V DC  
Page 5/1

-12V DC  
Page 3/70

1 2 3 4 5 6 7 8 9 10 11 12 13 14 15 16 17 18 19 20 21 22 23 24 25 26 27 28 29 30 31 32 33 34 35 36 37 38 39 40 41 42 43 44 45 46 47 48 49 50 51 52 53 54 55 56 57 58 59 60 61 62 63 64 65 66 67 68 69 70 71

3/50

18



Fjordgøvevej 21 Denmark  
6100 Haderslev  
Phone: +45 74 52 10 22  
Mail: info@x-yachts.com

Boattype: X-40 Classic Designer: John Morsing  
Project: Revision: 11.01.06

Date: 20-03-2007 Time: 08:11:27  
Page: 4



Cabin lights 2

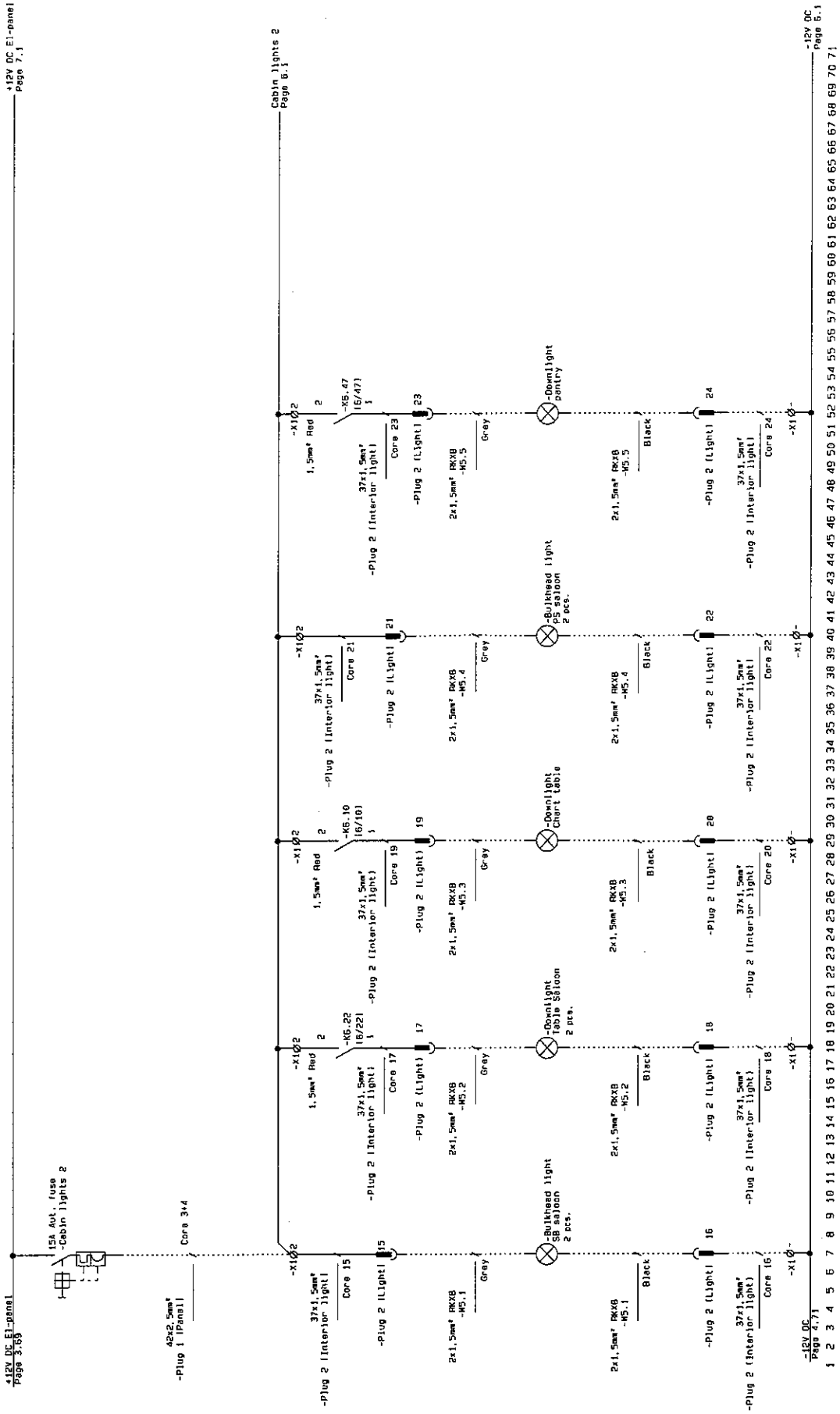

Cabin Lights 2.

Cabin\_Lights\_2  
Page 5,68

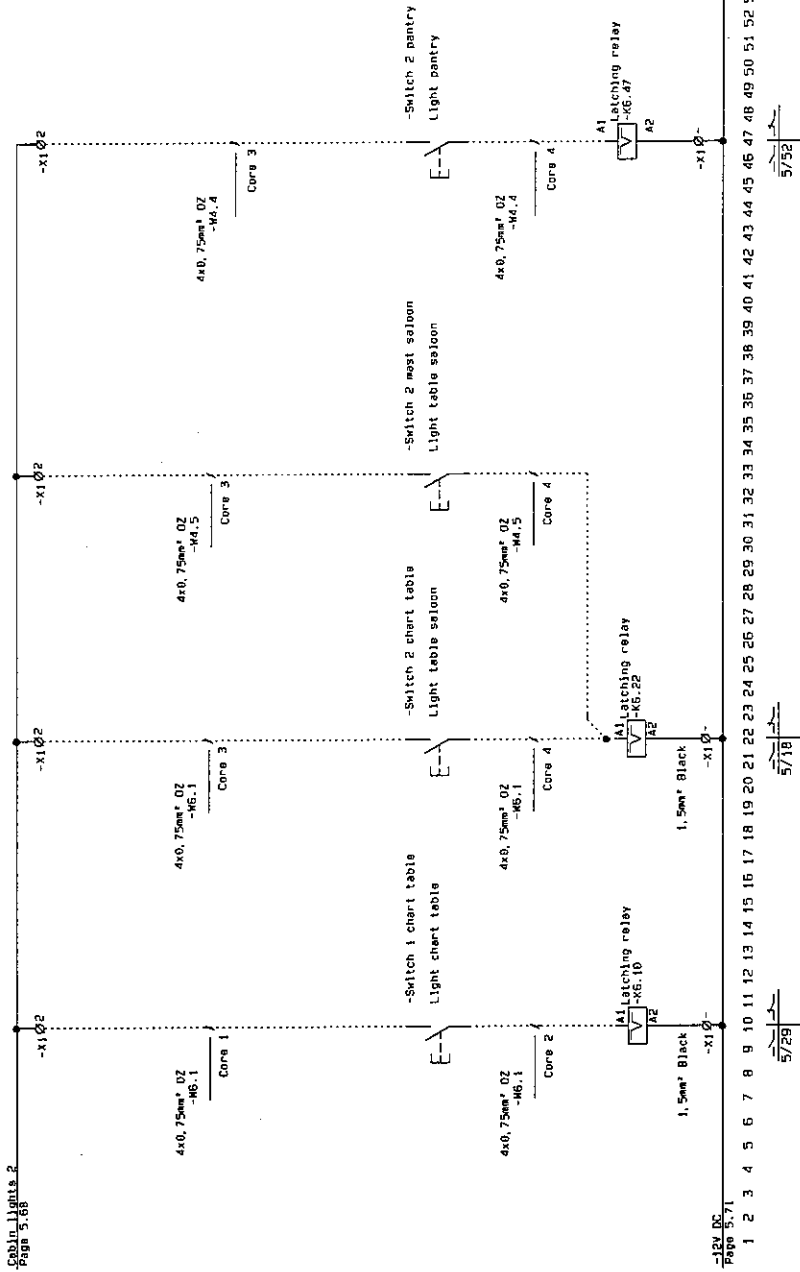

-12V DC  
Page 5,71

-12V DC  
Page 7,1

5/29

5/18

5/92

5/92

5/92

5/92

5/92

5/92

5/92

5/92

5/92

5/92

5/92

5/92

5/92

5/92

5/92

5/92

5/92



Fjordsgørvej 21  
6100 Haderslev Denmark  
Phone: +45 74 52 10 22  
Mail: info@x-yachts.com

Boattype: X-40 Classic  
Project: 11.01.06

Designer: John Morsing  
Revision: 11.01.06

Date: 20-03-2007  
Time: 08: 11:28  
Page: 6

Cabin lights 3

412V DC EI-Panel  
Page 6.71

412V DC EI-Panel  
Page 9.71

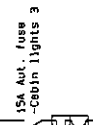

42x2 5mm²  
-Plug 1 (Panel)  
Core 5+6

Cabin Lights 3  
Page 6.71

Cabin Lights 3  
Page 9.71

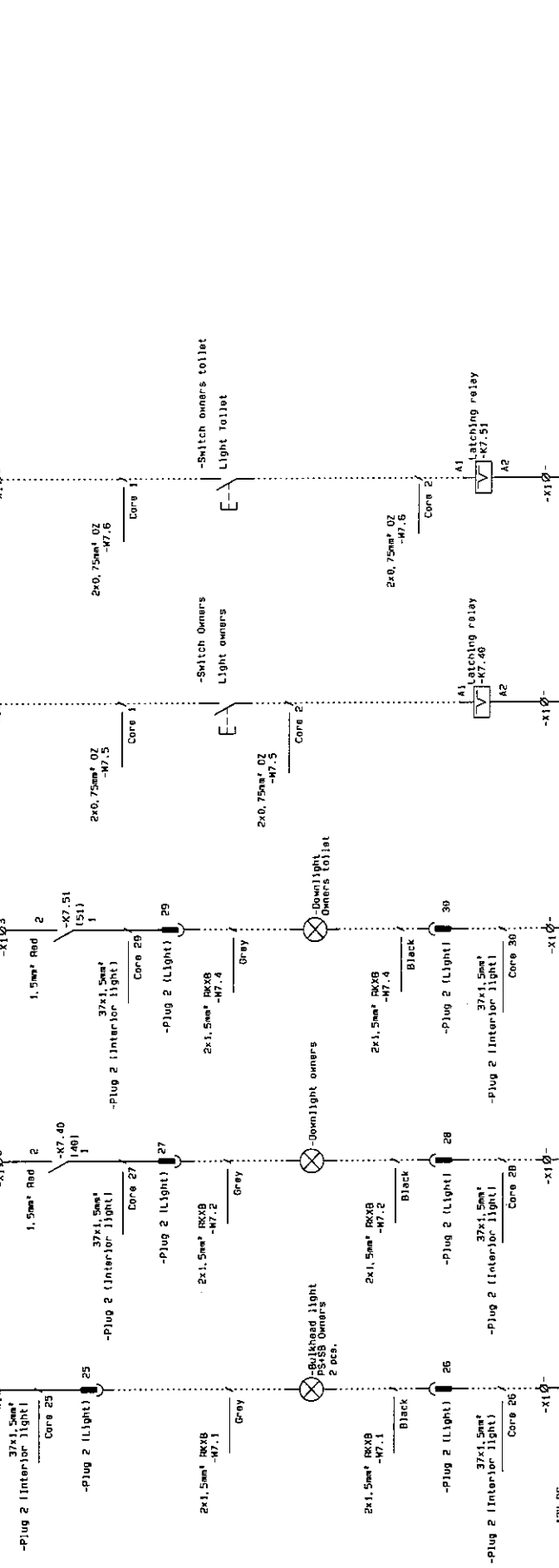

-12V DC  
Page 6.71

-12V DC  
Page 8.71

1 2 3 4 5 6 7 8 9 10 11 12 13 14 15 16 17 18 19 20 21 22 23 24 25 26 27 28 29 30 31 32 33 34 35 36 37 38 39 40 41 42 43 44 45 46 47 48 49 50 51 52 53 54 55 56 57 58 59 60 61 62 63 64 65 66 67 68 69 70 71



Fjordsgørvej 21 Denmark  
6100 Haderslev  
Phone: +45 74 52 10 22  
Mail: info@x-yachts.com

Boattype: X-40 Classic  
Designer: John Morsing  
Revision: 11.01.06

Date: 20-03-2007  
Time: 08:11:28  
Page: 7

Cabin lights 3

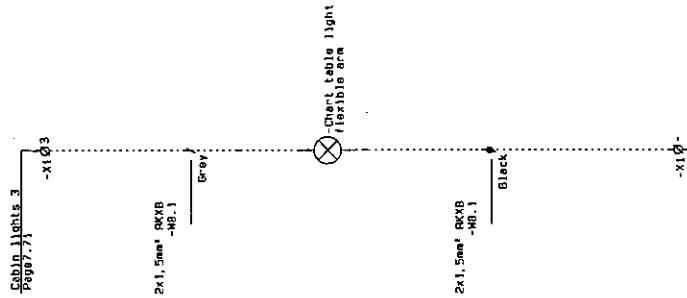

-12V DC  
Page 9,1

1 2 3 4 5 6 7 8 9 10 11 12 13 14 15 16 17 18 19 20 21 22 23 24 25 26 27 28 29 30 31 32 33 34 35 36 37 38 39 40 41 42 43 44 45 46 47 48 49 50 51 52 53 54 55 56 57 58 59 60 61 62 63 64 65 66 67 68 69 70 71



Fjordgørvvej 21  
6100 Haderslev Denmark  
Phone: +45 74 52 10 22  
Mail: info@x-yachts.com

Boattype: X-40 Classic  
Project:

Designer: John Morsing  
Revision: 11.01.05

Date: 20-03-2007  
Time: 08: 11:28  
Page: 8

Night-/Navigation-/Anchor-/windex-/Tri colour-- and Deck flood light

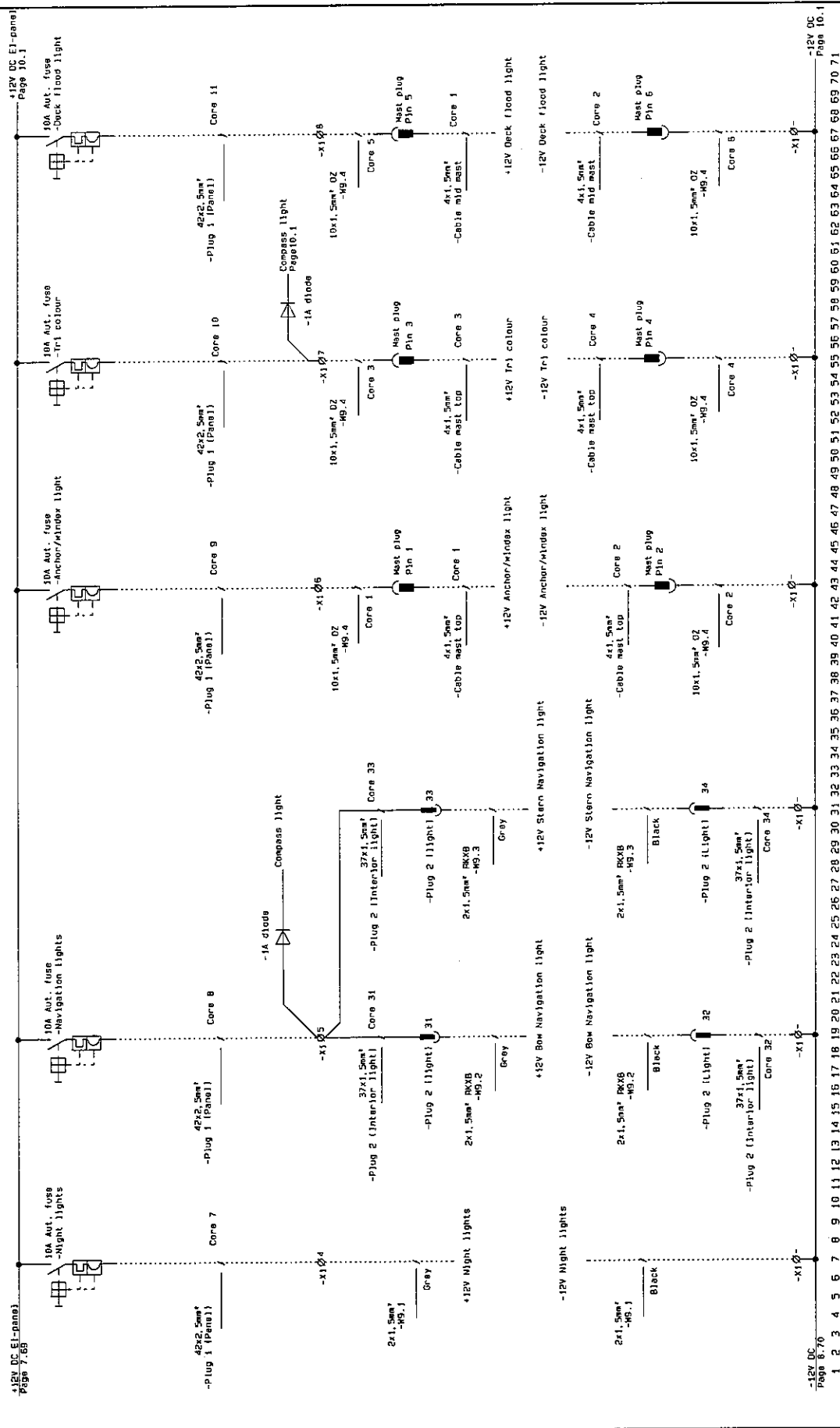

Compass - Steaming light / Radio Cd stereo / Instruments / autopilot / Radar / plotter / VHF

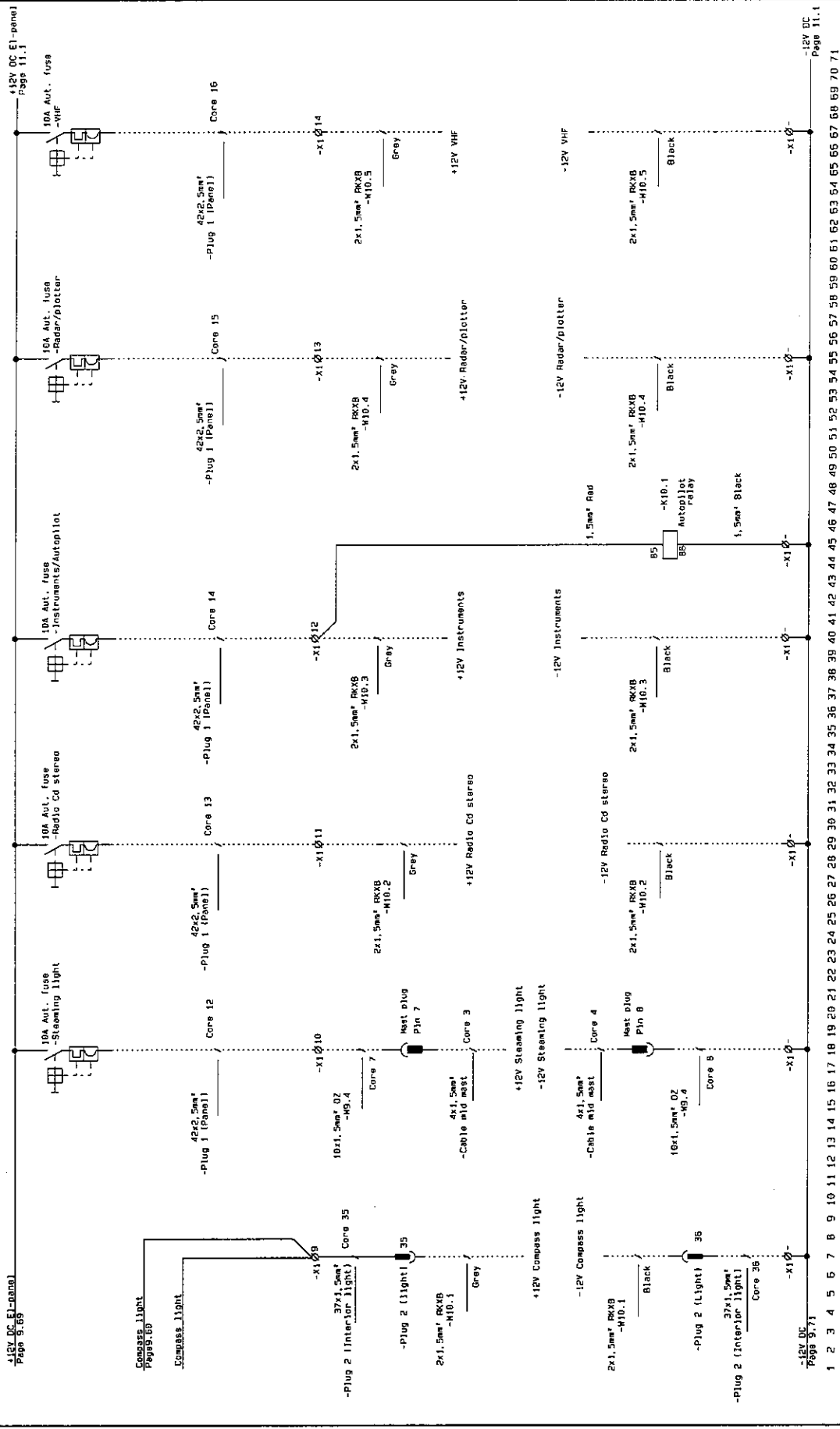

1 2 3 4 5 6 7 8 9 10 11 12 13 14 15 16 17 18 19 20 21 22 23 24 25 26 27 28 29 30 31 32 33 34 35 36 37 38 39 40 41 42 43 44 45 46 47 48 49 50 51 52 53 54 55 56 57 58 59 60 61 62 63 64 65 66 67 68 69 70 71



Fiordagervej 21  
 6400 Haderslev  
 Phone: +45 74 52 10 22  
 Mail: info@x-yachts.com

Refrigerator/freezer/Winches/bowthruster/fresh water/Sea water pump/Deck wash pump

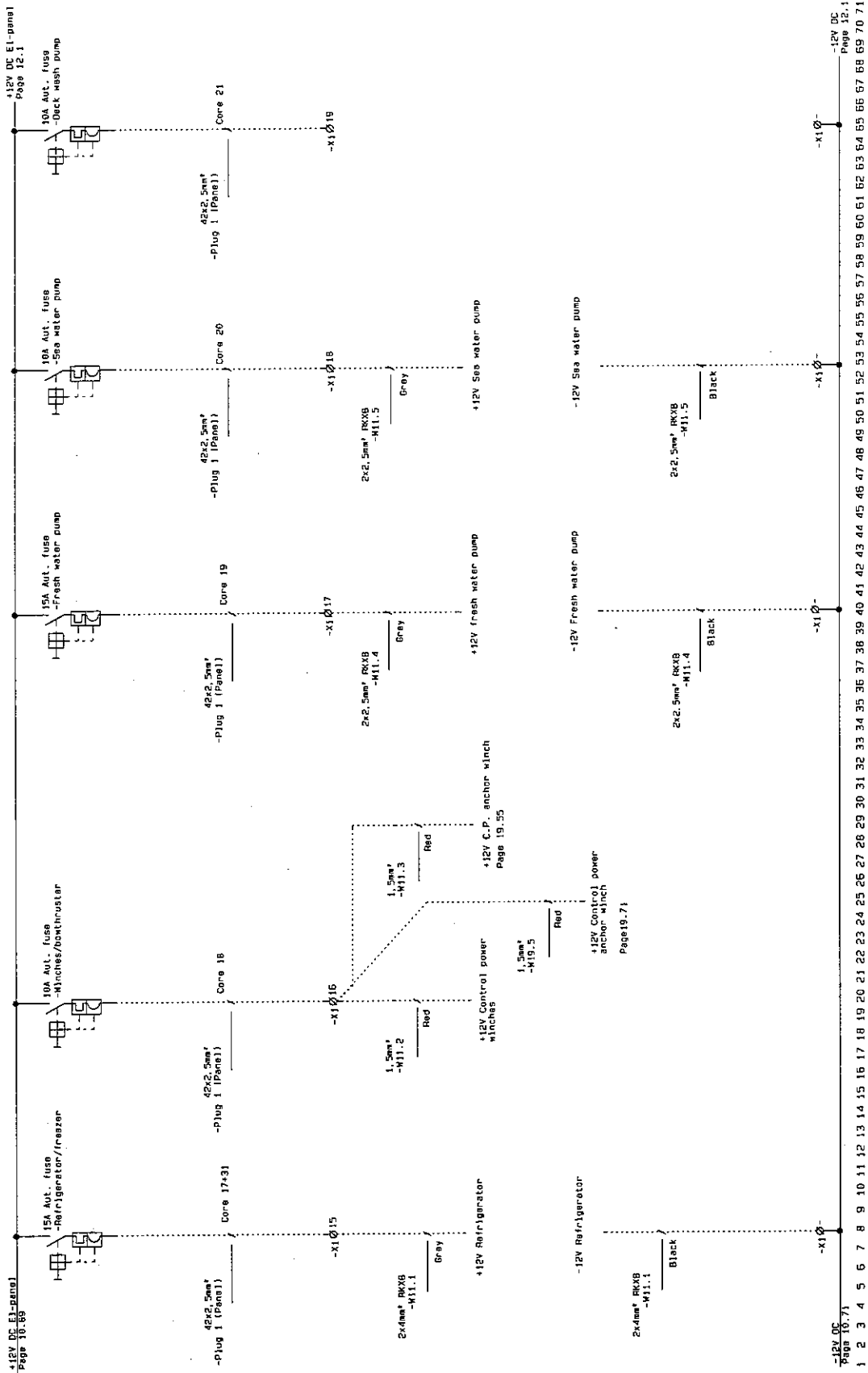

Shower sump pumps/keel sump pump

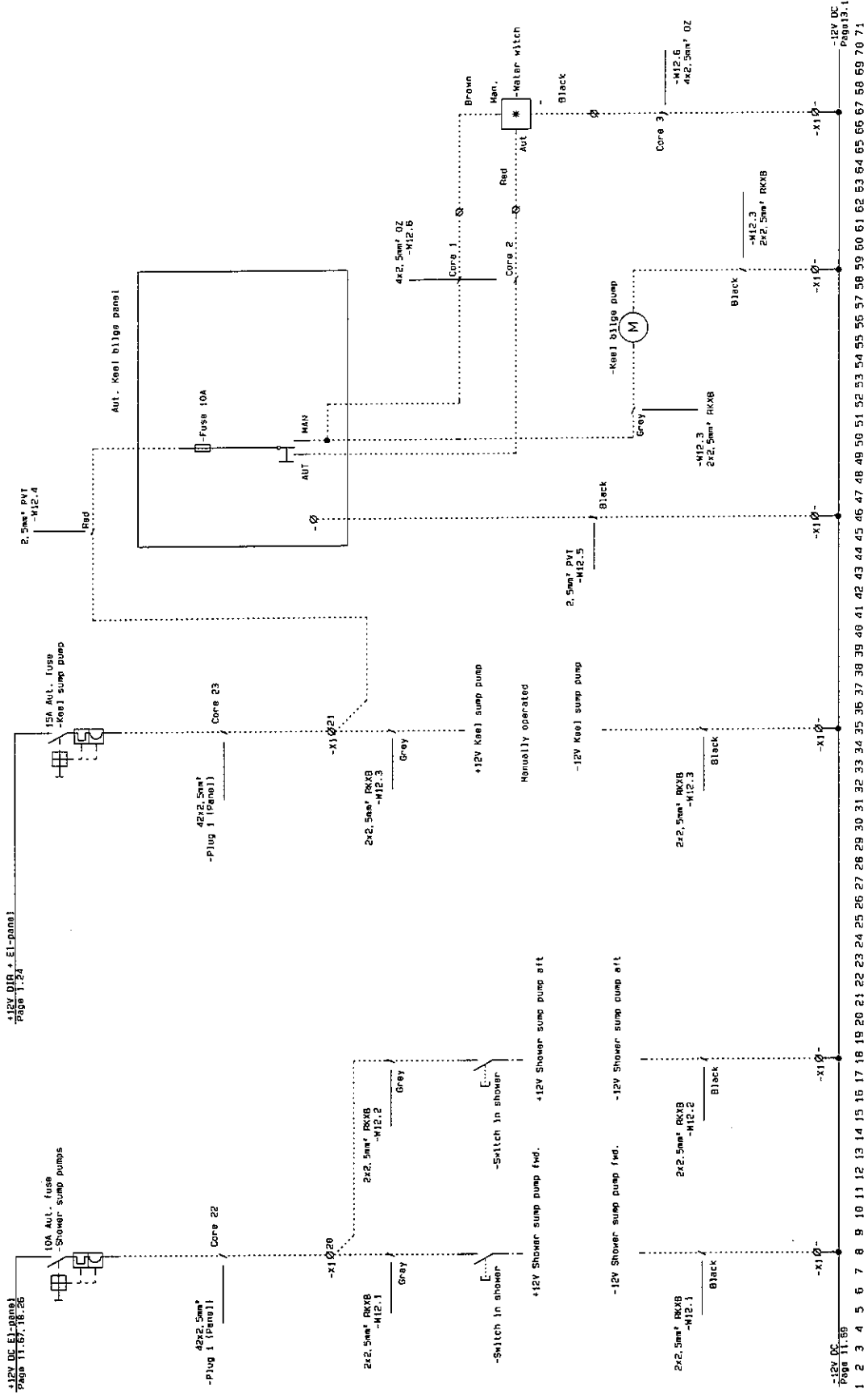



Level gauges black water tanks, Level 1

+12V DC E1-panel  
Page 15.1

+12V Tanktech/tanklevel  
Page 14.2

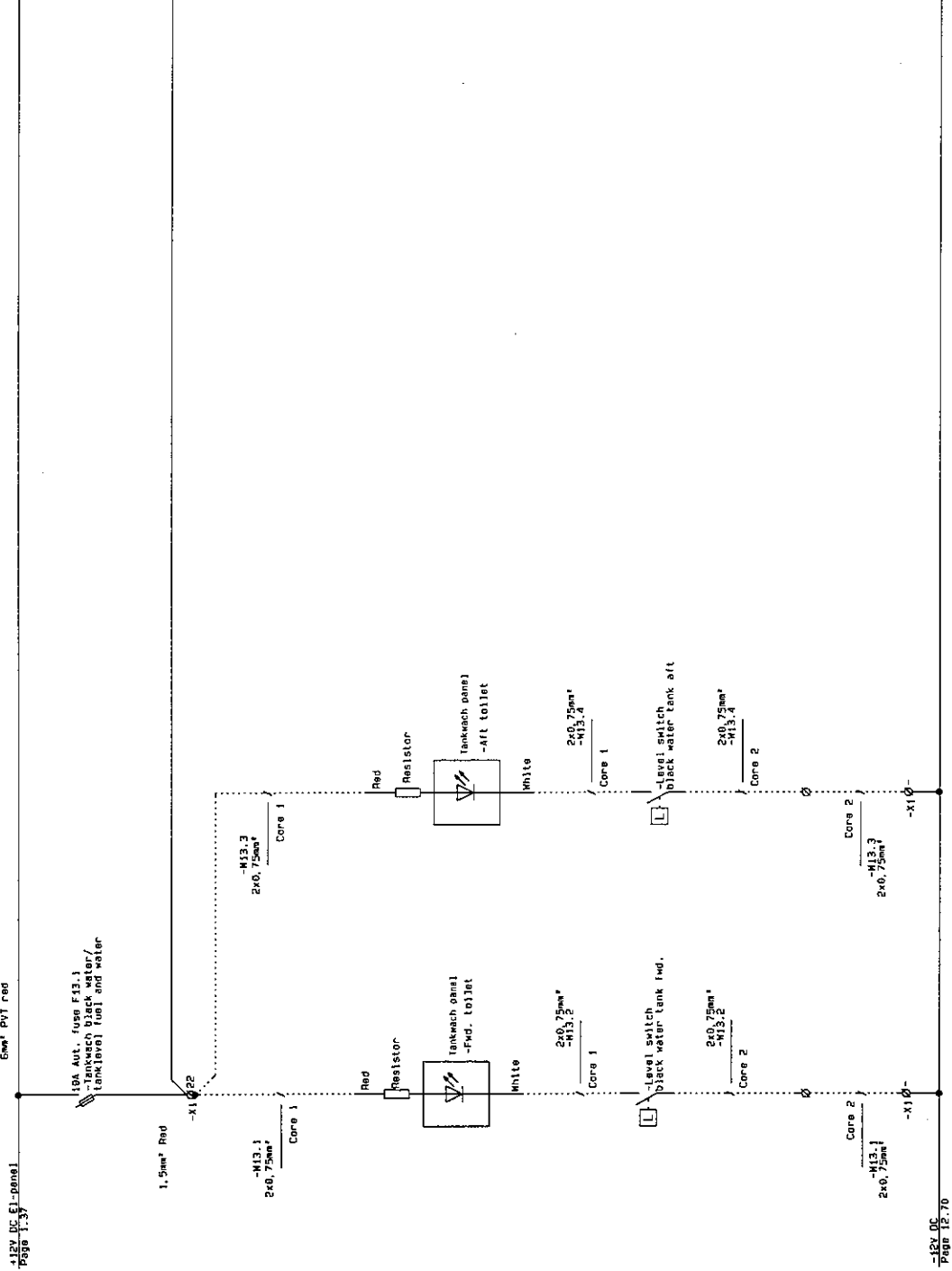

+12V DC  
Page 14.1

1 2 3 4 5 6 7 8 9 10 11 12 13 14 15 16 17 18 19 20 21 22 23 24 25 26 27 28 29 30 31 32 33 34 35 36 37 38 39 40 41 42 43 44 45 46 47 48 49 50 51 52 53 54 55 56 57 58 59 60 61 62 63 64 65 66 67 68 69 70 71



Fjordgørvej 21  
6100 Hederslev Denmark  
Phone: +45 74 52 10 22  
Mail: info@x-yachts.com

Boattype: X-40 Classic  
Designer: John Morsing  
Revision: 11.01.06

Date: 20-03-2007  
Time: 08:11:29  
Page: 13

# Tanklevel Fuel 1 and Fuel 2

+12V Tankwch/Tank level  
Page 13.61

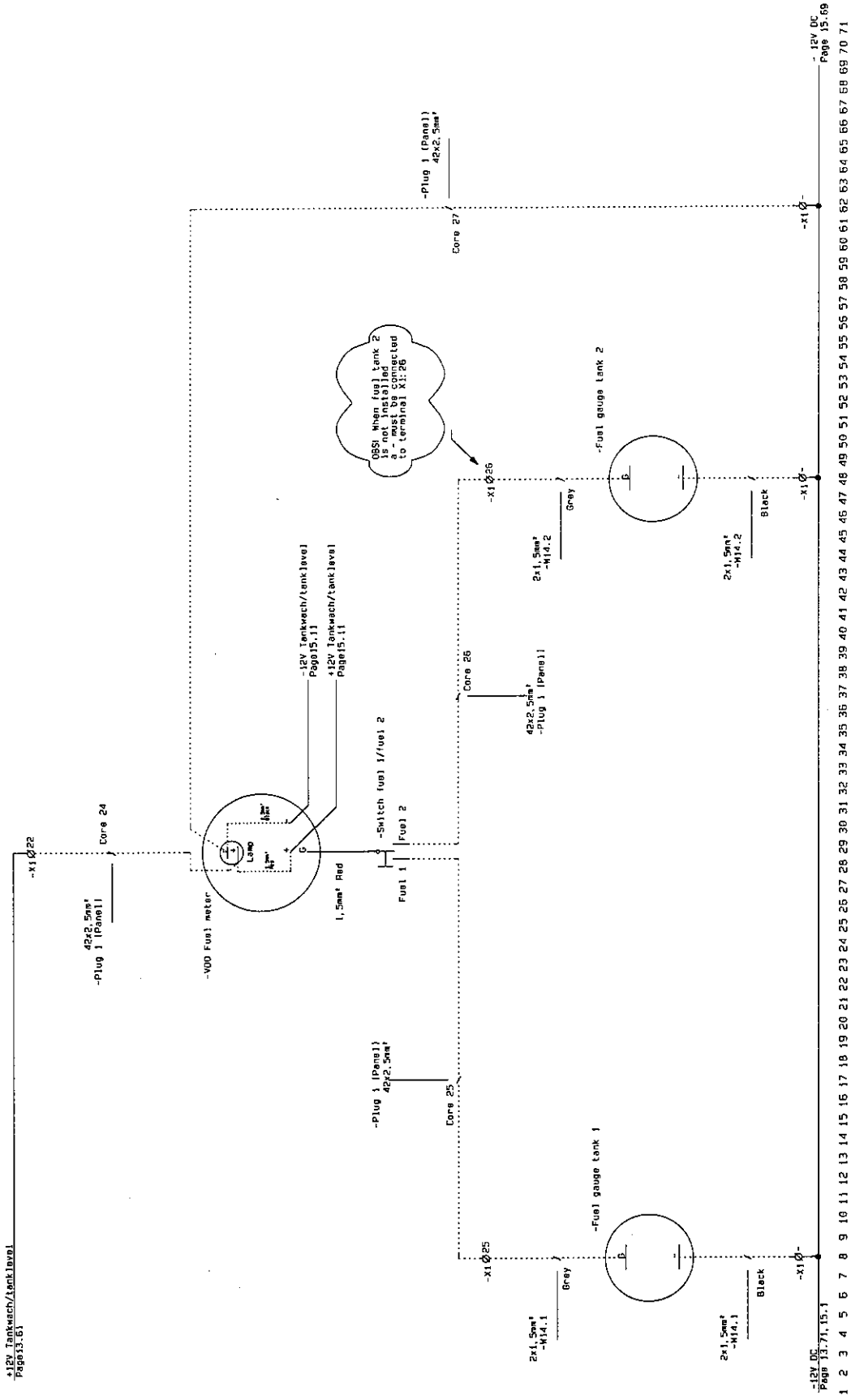

-12V DC  
Page 13.71.15.1

-12V DC  
Page 15.69

1 2 3 4 5 6 7 8 9 10 11 12 13 14 15 16 17 18 19 20 21 22 23 24 25 26 27 28 29 30 31 32 33 34 35 36 37 38 39 40 41 42 43 44 45 46 47 48 49 50 51 52 53 54 55 56 57 58 59 60 61 62 63 64 65 66 67 68 69 70 71



Fjordagervej 21 Denmark  
6100 Haderslev  
Phone: +45 74 52 10 22  
Mail: info@x-yachts.com

Boattype: X-40 Classic  
Project:

Designer: John Morsing  
Revision: 11.01.06

Date: 20-03-2007

Time: 08:11:29  
Page: 14

Tanklevel Water 1 and Water 2 / Voltmeter

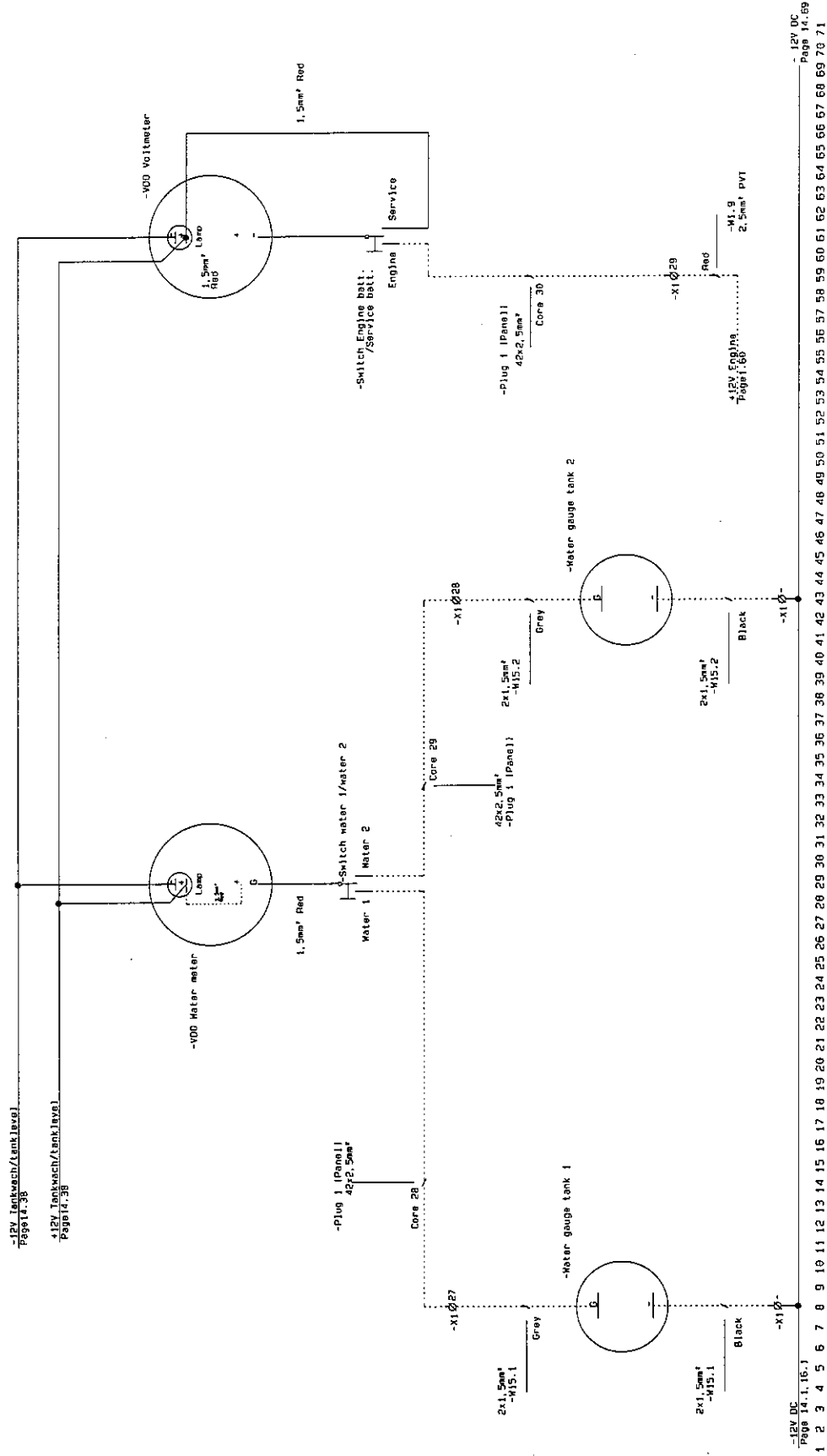

-12V Tank/water/tank level  
Page 14.69

-12V Tank/water/tank level  
Page 14.69

-Plug 1 (Panel)  
42x2.5mm²

2x1.5mm²  
-W15.1

2x1.5mm²  
-W15.1

-12V DC  
Page 14.1, 16.1

-12V DC  
Page 14.69

1 2 3 4 5 6 7 8 9 10 11 12 13 14 15 16 17 18 19 20 21 22 23 24 25 26 27 28 29 30 31 32 33 34 35 36 37 38 39 40 41 42 43 44 45 46 47 48 49 50 51 52 53 54 55 56 57 58 59 60 61 62 63 64 65 66 67 68 69 70 71



Fjordgørvej 21  
6100 Haderslev Denmark  
Phone: +45 74 52 10 22  
Mail: info@x-yachts.com

Boattype: X-40 Classic  
Project: 11.01.06

Designer: John Morsing  
Revision: 11.01.06

Date: 20-03-2007  
Time: 08: 11: 29  
Page: 15

12V Socket / Autopilot/NMEA data plug and NMEA bridge

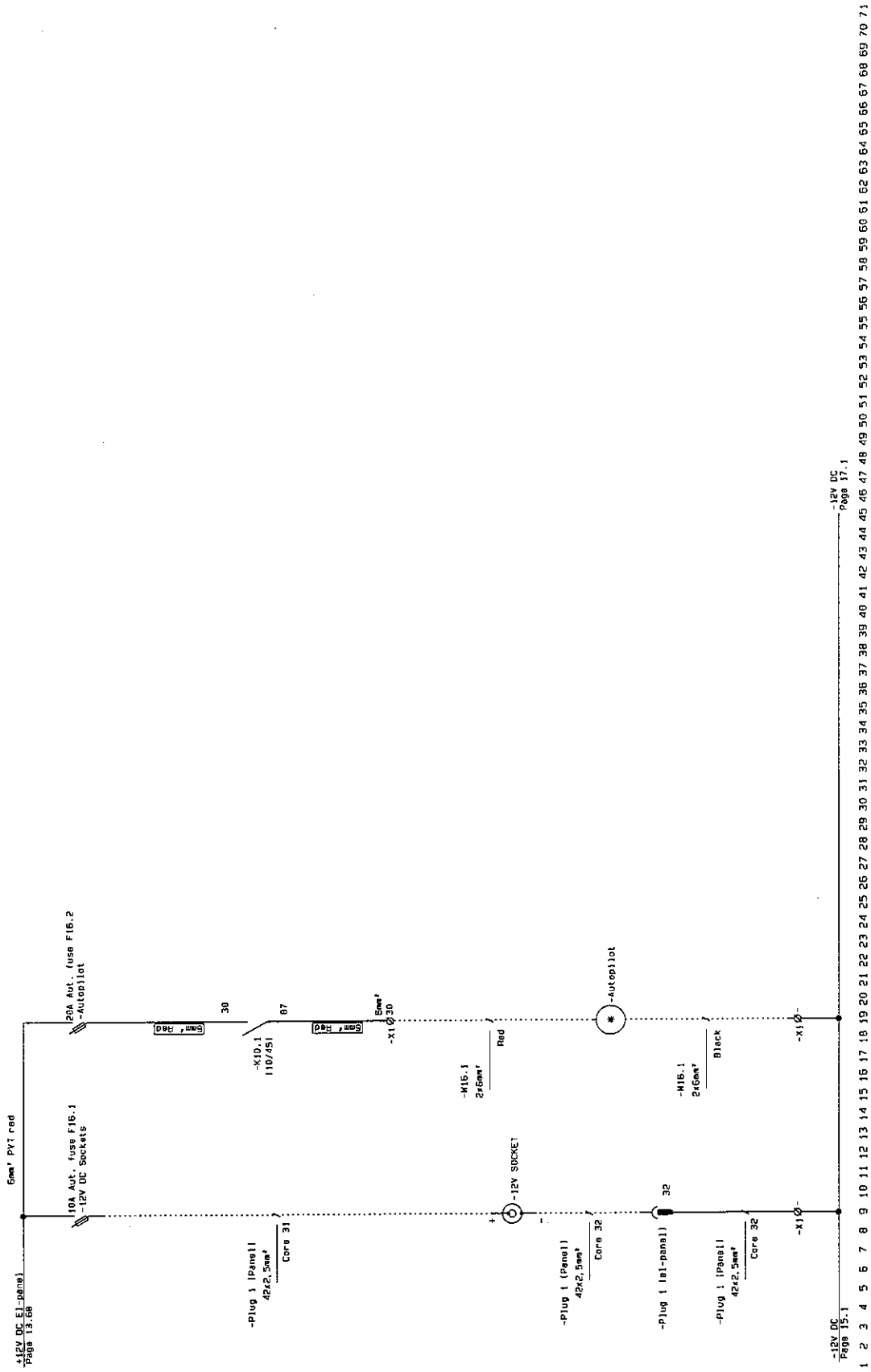

1 2 3 4 5 6 7 8 9 10 11 12 13 14 15 16 17 18 19 20 21 22 23 24 25 26 27 28 29 30 31 32 33 34 35 36 37 38 39 40 41 42 43 44 45 46 47 48 49 50 51 52 53 54 55 56 57 58 59 60 61 62 63 64 65 66 67 68 69 70 71

-12V DC  
Page 17.1



Fjordagervej 21 Denmark  
6100 Haderslev  
Phone: +45 74 52 10 22  
Mail: info@x-yachts.com

Boattype: X-40 Classic Designer: John Morsing  
Project: Revision: 11.01.06

Date: 20-03-2007 Time: 08:11:29  
Page: 16

Heater/Dir+ Radio Cd stereo/Gas detector/Gas switch

12V DIR + EI-panels  
Page 18.21

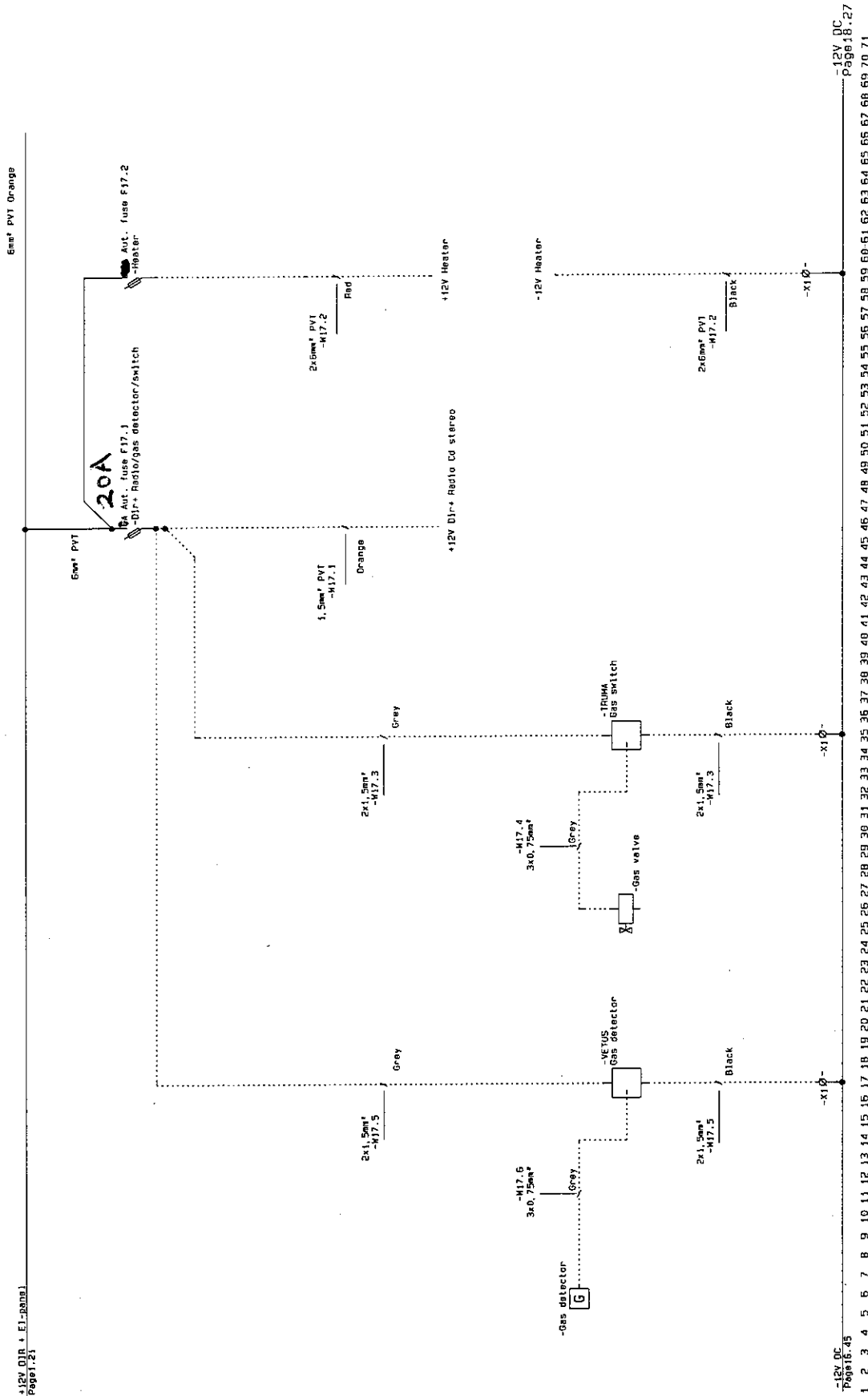

12V DC  
Page 18.27

12V DC  
Page 18.45

1 2 3 4 5 6 7 8 9 10 11 12 13 14 15 16 17 18 19 20 21 22 23 24 25 26 27 28 29 30 31 32 33 34 35 36 37 38 39 40 41 42 43 44 45 46 47 48 49 50 51 52 53 54 55 56 57 58 59 60 61 62 63 64 65 66 67 68 69 70 71

	Fjordgørvej 21 Denmark 6100 Haderslev Phone: +45 74 52 10 22 Mail: info@x-yachts.com	Designer: John Morsing Revision: 11.01.06	Date: 20-03-2007 Time: 08:11:29
	Boattype: X-40 Classic Project:	Page: 17	

# Engine room ventilation

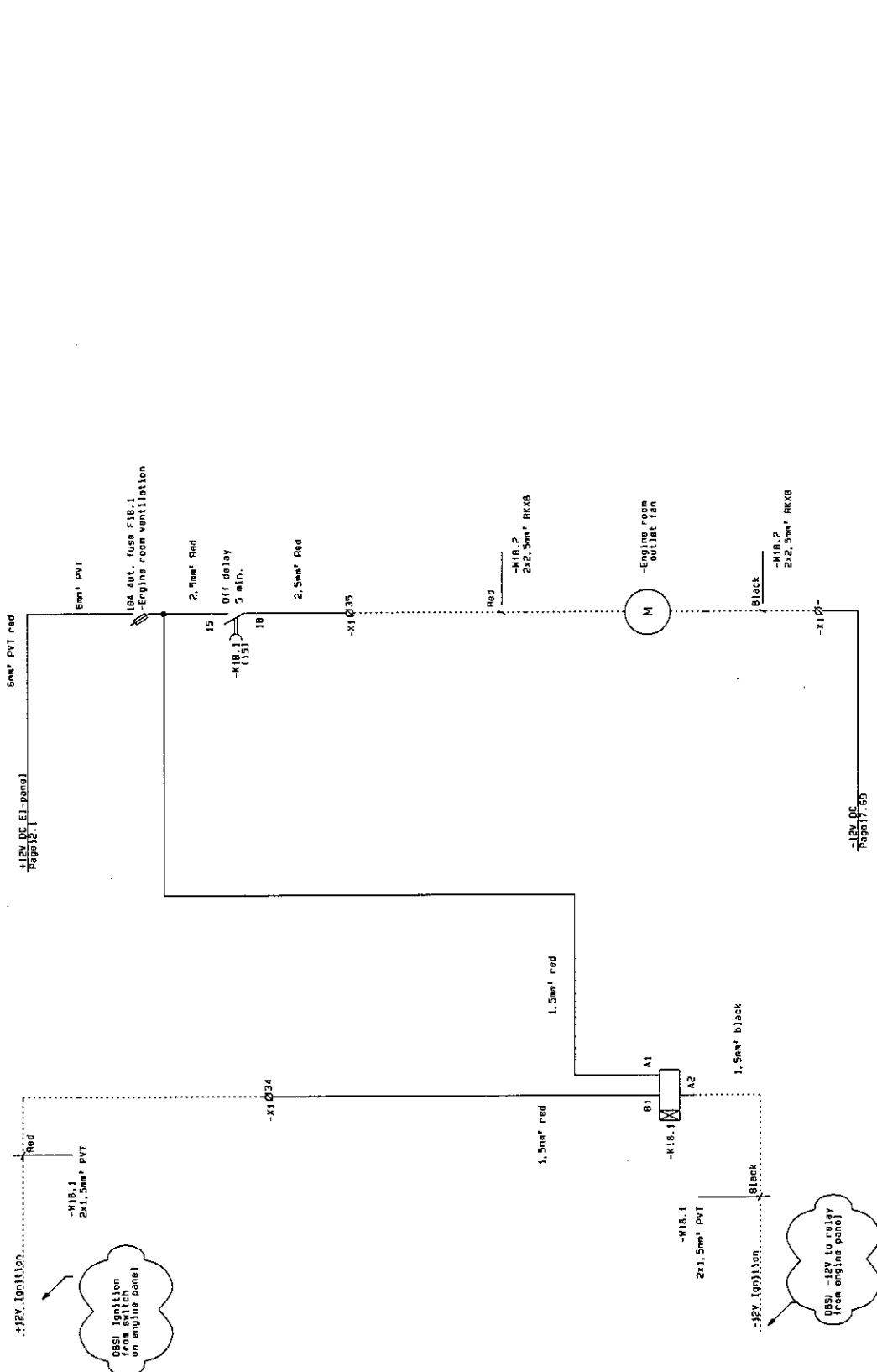

1 2 3 4 5 6 7 8 9 10 11 12 13 14 15 16 17 18 19 20 21 22 23 24 25 26 27 28 29 30 31 32 33 34 35 36 37 38 39 40 41 42 43 44 45 46 47 48 49 50 51 52 53 54 55 56 57 58 59 60 61 62 63 64 65 66 67 68 69 70 71

	Fiordagervej 21 Denmark 5100 Haderslev Phone: +45 74 52 10 22 Mail: info@x-yachts.com	Boattype: X-40 Classic	Designer: John Morsing	Date: 20-03-2007	Time: 08:11:29
		Project:	Revision: 11.01.06		

Anchor winch Lofrans

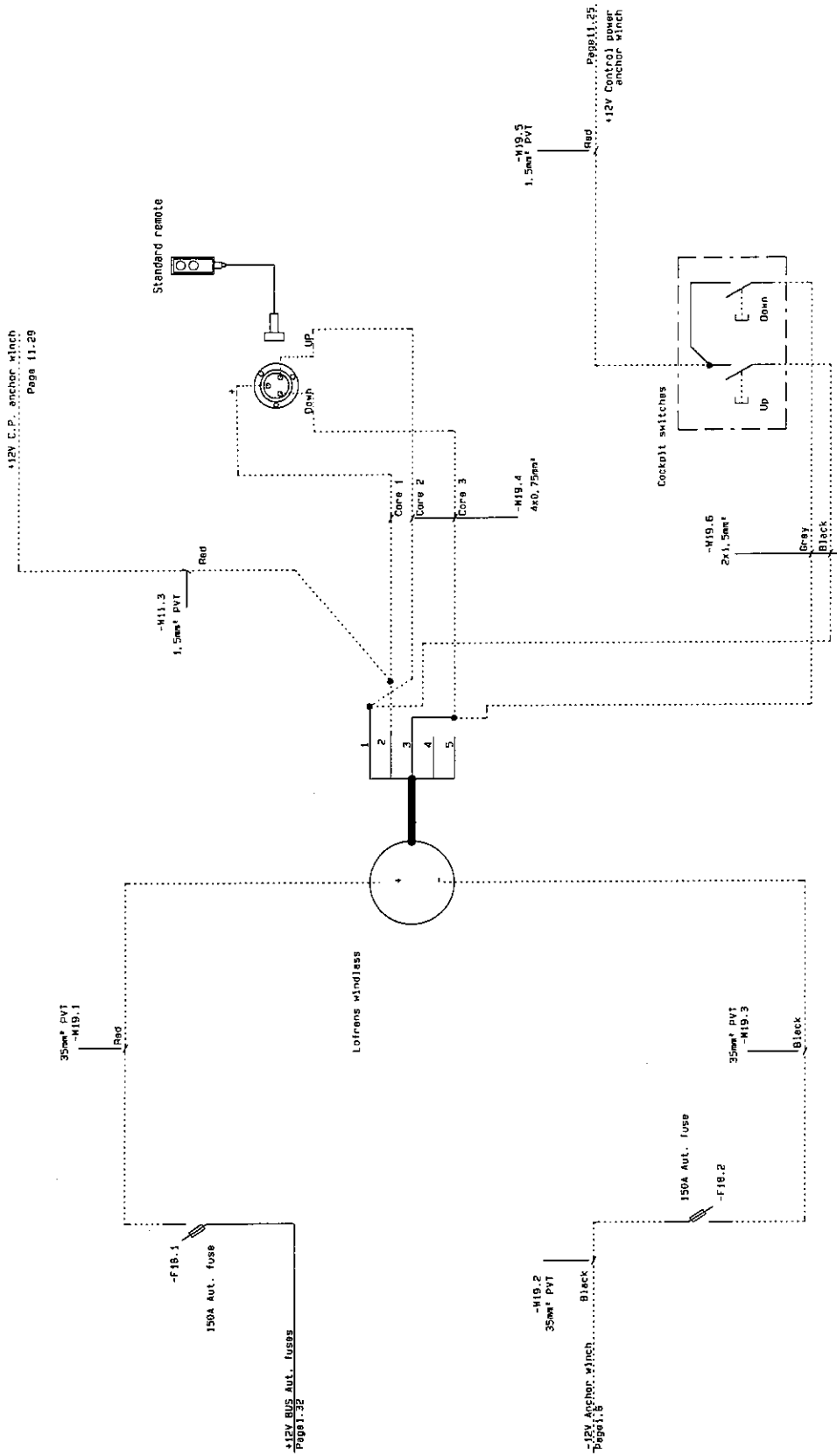

12V E.P. anchor winch  
Page 11.29

1 2 3 4 5 6 7 8 9 10 11 12 13 14 15 16 17 18 19 20 21 22 23 24 25 26 27 28 29 30 31 32 33 34 35 36 37 38 39 40 41 42 43 44 45 46 47 48 49 50 51 52 53 54 55 56 57 58 59 60 61 62 63 64 65 66 67 68 69 70 71



Fjordgørvej 21 Denmark  
6100 Haderslev  
Phone: +45 74 52 10 22  
Mail: info@x-yachts.com

Boattype: X-40 Classic Designer: John Morsing  
Project: Revision: 11.01.05

Date: 20-03-2007 Time: 08:11:29  
Page: 19

Spare (Electrical winches)

1 2 3 4 5 6 7 8 9 10 11 12 13 14 15 16 17 18 19 20 21 22 23 24 25 26 27 28 29 30 31 32 33 34 35 36 37 38 39 40 41 42 43 44 45 46 47 48 49 50 51 52 53 54 55 56 57 58 59 60 61 62 63 64 65 66 67 68 69 70 71



Fjordagervej 21 Denmark  
6100 Haderslev  
Phone: +45 74 52 10 22  
Mail: info@x-yachts.com

Boattype: X-40 Classic

Designer: John Morsing

Revision: 11.01.06

Date: 20-03-2007

Time: 08:11:29

Page: 20



230V AC shore power inlet and shore power main fuse

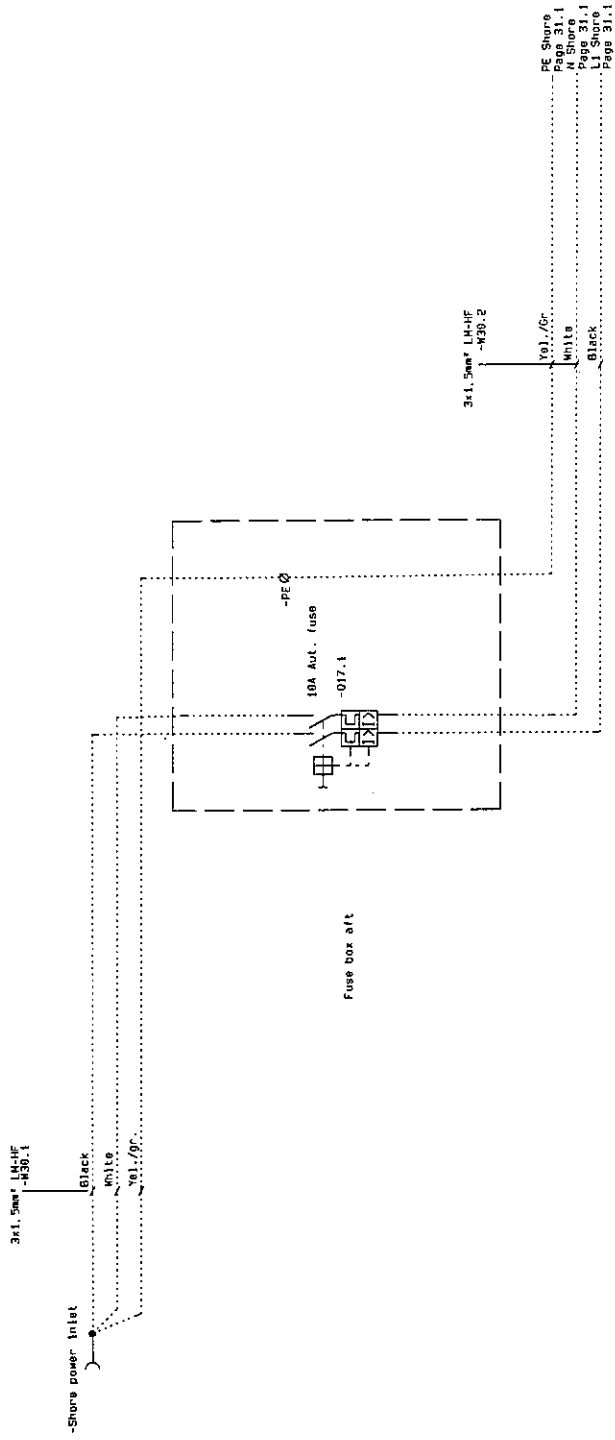

1 2 3 4 5 6 7 8 9 10 11 12 13 14 15 16 17 18 19 20 21 22 23 24 25 26 27 28 29 30 31 32 33 34 35 36 37 38 39 40 41 42 43 44 45 46 47 48 49 50 51 52 53 54 55 56 57 58 59 60 61 62 63 64 65 66 67 68 69 70 71

	Fjordgærvej 21 6100 Haderslev Denmark Phone: +45 74 52 10 22 Mail: info@x-yachts.com	Designer: John Morsing Date: 20-03-2007	Time: 08:11:29
	Boettype: X-40 Classic Project:	Revision: 11.01.06	Page: 30

230V AC Dist. box (Only shore power)

-230V DIST. BOX  
PHILLIPPI

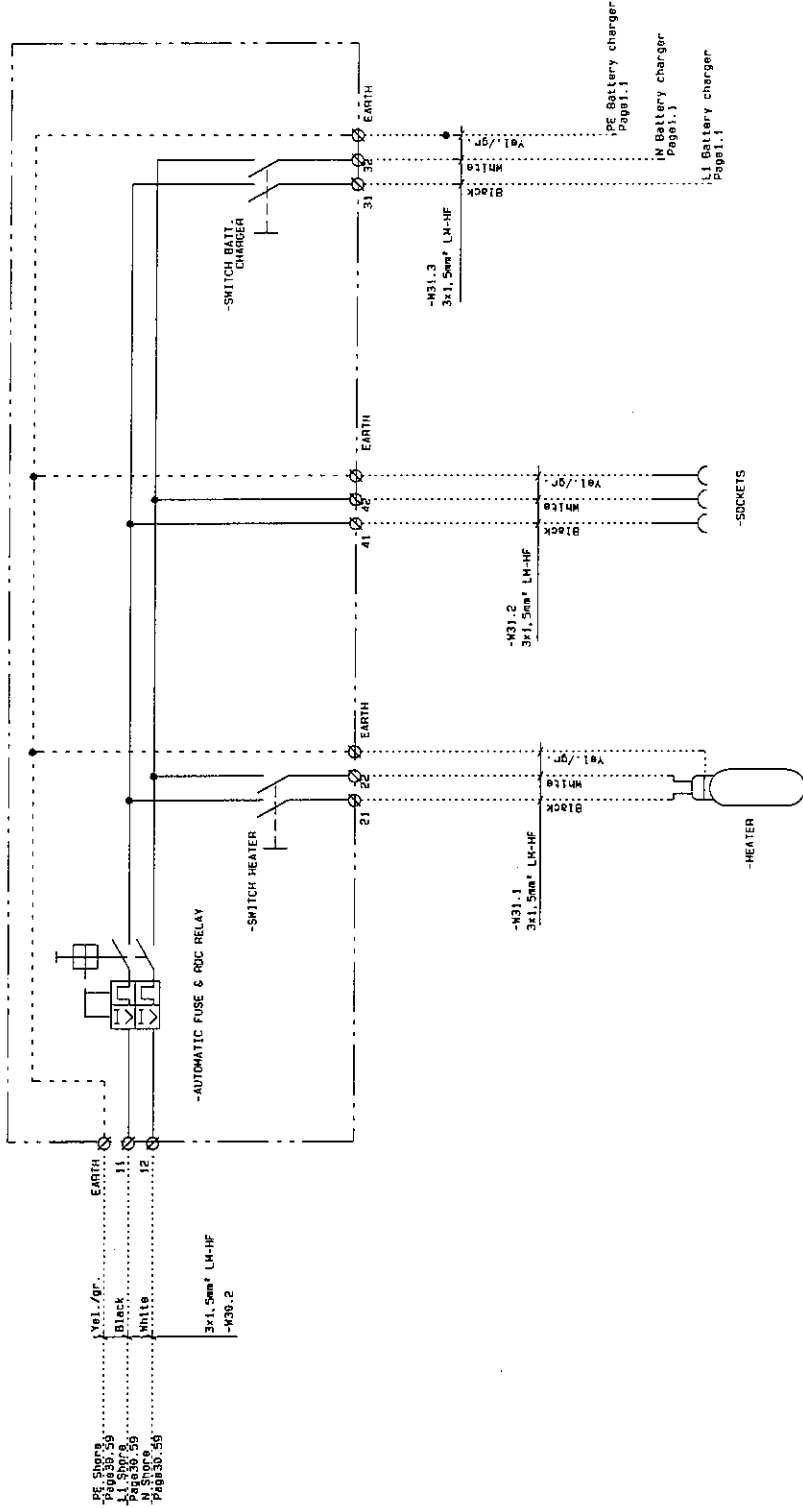

1 2 3 4 5 6 7 8 9 10 11 12 13 14 15 16 17 18 19 20 21 22 23 24 25 26 27 28 29 30 31 32 33 34 35 36 37 38 39 40 41 42 43 44 45 46 47 48 49 50 51 52 53 54 55 56 57 58 59 60 61 62 63 64 65 66 67 68 69 70 71



Fjordagervej 21  
5100 Haderslev Denmark  
Phone: +45 74 52 10 22  
Mail: info@x-yachts.com

Boattype: X-40 Classic Designer: John Morsing  
Project: Revision: 11.01.06

Date: 20-03-2007 Time: 08:11:29  
Page: 31